



The Forest Professional

**Guidelines for
the Stewards of
tomorrow's forests
(Fourth Edition)**



The Forest Professional

Guidelines for the Stewards of tomorrow's forests (Fourth Edition)

Describing practical techniques and procedures
for good forest operations

Occupational Health and Safety Division
Department of Environment and Labour
Nova Scotia

Prevention Services
**Workplace Health, Safety and Compensation
Commission of New Brunswick**

Occupational Health and Safety Services
Workers' Compensation Board
Prince Edward Island

Health and Safety Services
**Workplace Health, Safety and Compensation Commission
of Newfoundland and Labrador**

Canadian Cataloguing in Publication Data

Main entry under title :

The Forest Professional - guidelines
for the Stewards of tomorrow's forests,
Fourth Edition
ISBN 1-55457-025-5

1. Forests and forestry — Safety measures — Handbooks, manuals, etc. I. Nova Scotia. Occupational Health and Safety Division. Workplace Health, Safety and Compensation Commission of New Brunswick. Workplace Health, Safety and Compensation Commission of Newfoundland and Labrador. PEI Worker's Compensation Board. II. Nova Scotia Forest Products Association. Safety and Training Committee.

SD 387.S3P76 1994 363.11'96349 C94-966001-9

Printed in Canada

© Province of Nova Scotia, 2005

Published by the
Nova Scotia Department of Environment and Labour

Printed on paper that
contains recycled fibre

The agencies in the Atlantic Provinces responsible for workplace health and safety recognize the importance of providing information to help their clients to comply with the legislation and of developing good industry practices that will promote safe and healthy workplaces.

This manual has been produced by the Occupational Health and Safety Division, Nova Scotia Department of Environment and Labour with the co-operation of the Atlantic jurisdictions, adapted from material prepared by the Safety and Training Committee, Nova Scotia Forest Products Association.

This document was submitted and reviewed by the Occupational Health and Safety agencies from the Atlantic Provinces as part of the Conference of Atlantic Premiers Harmonization of Occupational Safety and Health initiative.

Although this document is intended to represent acceptable industry practice that will promote safe work practices, there may be a conflict with legal standards in any specific jurisdiction. The appropriate provincial laws must be followed whenever the text of this booklet and the laws differ.

The Nova Scotia Department of Environment and Labour is responsible for updating this publication. In an attempt to keep this publication current we would ask for your assistance. If you have comments that should be considered in the next version of the document, please complete and return the form found in the back of the publication.

The agencies responsible for workplace health and safety in the Atlantic Provinces hope that this document will be of assistance to you in improving health and safety performance in the forestry sector.

New Brunswick

This document can be used for information regarding safe work practices. However, Regulation 91-191 requires different practices in some areas. The New Brunswick Workplace Health Safety and Compensation Commission has also developed a video on basic safety in forestry operations which is available free of charge.

Newfoundland and Labrador

This document can be used for information regarding acceptable industry practice.

Nova Scotia

This document can be used for information regarding acceptable industry practice.

Prince Edward Island

This document can be used for information regarding acceptable industry practice.

In all cases, the legislation of the province in which you work takes precedence over this guideline document. If you have questions, review the appropriate regulations or consult with your occupational health and safety agency.

ATLANTIC OCCUPATIONAL SAFETY AND HEALTH AGENCIES

Prevention Services
**Workplace Health, Safety and Compensation
Commission of New Brunswick**
500 Beaverbrook Court
Fredericton, NB
E3B 5X4
Telephone: (506)-453-2467
1-800-442-9776
Fax: (506)-453-7982
Website: www.whscc.nb.ca

New Brunswick

Occupational Health and Safety Division
**Workers' Compensation Building
Workers' Compensation Board**
Prince Edward Island
PO Box 2000
Charlottetown, PE
C1A 7N8
Telephone: (902) -368-5562
Fax: (902) -368-5696
www.wcb.pe.ca

Prince Edward Island

Occupational Health and Safety Division
**Nova Scotia Department of
Environment and Labour**
5151 Terminal Road, 6th Floor
PO Box 697
Halifax, NS
B3J 1A1
Telephone: (902) -424-5400
1-800-952-2687 (9-LABOUR—Nova Scotia only)
Fax: (902) -424-5640
E-mail: labrohs@gov.ns.ca
Website: www.gov.ns.ca/enla/healthandsafety

Nova Scotia

Health and Safety Services
**Workplace Health, Safety and Compensation
Commission of Newfoundland and Labrador**
146–148 Forest Road
PO Box 9000
St. John's, NF
A1A 3B8
Telephone: (709) -778-1000
Fax: (709) -778-1564
Website: www.whscc.nf.ca
E-mail: lcollins@whscc.nf.ca

Newfoundland and Labrador

**Human Resources Development Canada—
Labour Program (Federal Workplaces)**

PO Box 1166

Moncton, NB

E1C 8L4

Telephone: (506) -851-6640

Fax: (506) -851-6645

99 Wyse Road

Dartmouth, NS

B3A 1L9

Telephone: (902) -426-4995

Fax: (902) -426-1390

PO Box 850

Sydney, NS

B1P 6J3

Telephone: (902) -564-7130

Fax: (902) -564-7131

PO Box 8000

Charlottetown, PE

C1A 8K1

Telephone: (902) -566-7171

Fax: (902) -566-7699

PO Box 8548

St. John's, NF

A1B 3P3

Telephone: (709) -772-5022

Fax: (709) -772-5985

Protective Equipment and Clothing	11
What You Need	11
Standards and Care Required	14
Hard hat	14
Safety footwear	14
Hearing protectors	14
Leg protection	14
Gloves or mitts	14
Equipment for chemical application	14
Supervising Employees	15
Equipment Training	15
Equipment Operation	15
Supervision	15
Employee Responsibilities	16
Housekeeping	16
Reporting Accidents	17
Chain Saws	18
Safety Check	18
Chain brake	19
Throttle-control lock out	19
Anti-vibration mounts	19
Rear hand guard	19
Chain catcher	19
Guide bar	19
Spark arrestor	19
Sprocket-nose guide bar	19
On/off switch	19
Safety chain	19
Filing techniques	20
Trouble-shooting	21
Operating a Chain Saw	23
To start	23
Position of hands	24
Speed	24
Position of saw	25
Carrying the saw	25
Components	25
Refueling	26
Storage and transportation of flammable material	26
Fire protection	26

Clearing Saws	27
Standards Required	27
Safety check	27
Throttle control lockout	27
Anti-vibration mounts	27
On/Off switch	27
Spark arrestor	27
Proper blade	28
Blade lock nut	28
Cutting Attachments	29
Sharpening the Blade	30
Making a sharpening post	30
Filing angle	30
Cutting Techniques	32
Blade position	32
Tilt or angle of blade	33
Direction of approach	34
Stump height	34
Directional felling	34
Mobile Equipment	35
Standards Required	35
Rollover requirements	35
Modifications	35
Seat belts	35
Equipment not built by manufacturer	35
Debris	35
Head boards	35
Climbing, walking, and working surfaces	35
Christmas tree balers	35
Fire protection	36
Brakes	36
Steering	36
Warning devices	36
Operating Mobile Equipment	37
Safety check	37
Refueling	37
Unattended equipment	37
Swinging equipment	37
Excess items	37
Slopes	37

Passengers _____	38
Transportation of flammable materials, tools, equipment _____	38
Maintaining Mobile Equipment _____	38
Modifications and repairs _____	38
Moving parts _____	38
Tire inflation _____	38
Hand tools _____	39
Blocking _____	39
Servicing _____	39
Correct Logging Procedures _____	40
Before Felling _____	40
Prelimbing a Standing Tree _____	41
Step 1 _____	41
Step 2 _____	41
Felling _____	42
Felling principles _____	42
The notch _____	42
Felling cut _____	43
Hinge _____	43
When the tree starts to fall _____	44
Preventing barber chairs _____	44
Partially cut or lodged trees _____	46
Dead or Dying Trees _____	47
Snags _____	47
Cavity trees _____	47
Cutting Spring Poles _____	47
Limbing _____	48
Before you begin _____	48
Position of saw _____	49
Beware _____	50
Six Step Limbing Method _____	51
Bucking _____	53
Yarding _____	54
When yarding with animals _____	54
When choking logs or trees _____	54
Grappling or winching logs or trees _____	54
Wire rope lines _____	54
Lifting Wood _____	55
Hauling, Loading, and Piling Wood on Vehicles _____	55

Working near Power Lines	56
Planning your work	56
Ground clearance	56
Crossing under power lines	57
Cutting near power lines	58
Tree contact with power lines	59
Equipment contact with power lines	60
Rescuing a co-worker	60
Woods Roads	61
Maintenance	61
Posting signs	61
Temporary workplace traffic control	61
New Brunswick	61
Newfoundland and Labrador	61
Nova Scotia	62
Prince Edward Island	62
Public roads	62
Forestry access roads	62
First Aid	65
Personal Hygiene	65
Glossary	66
Acts and Regulations	70
Occupational Health and Safety	
Legislative Framework	70
The Acts	71
Regulations	72
Codes of practice	73
Guidelines	73
Provincial legislation	74
New Brunswick	74
Newfoundland and Labrador	74
Nova Scotia	75
Prince Edward Island	76

Protective Equipment and Clothing

As a professional forestry worker, you must wear protective equipment and clothing when you are working. Whenever possible, all the forest industry equipment you use in the Atlantic Provinces should be approved by the Canadian Standards Association (CSA) or equivalent. In New Brunswick, CSA-approved footwear is mandatory. The following chart shows you what you need:

What You Need

Wear

- CSA-approved hard hat
- hearing protectors
- face screen and/or safety goggles or safety glasses
- leg protection that is resistant to chain saw cuts
- CSA Grade 1 boots or equivalent; chain saw boots are recommended
- carry pressure bandage

- CSA-approved hard hat
- hearing protectors
- face screen and/or safety goggles or safety glasses
- CSA Grade 2 boots or equivalent
- carry pressure bandage

- CSA-approved hard hat
- leg protection that is resistant to knife cuts
- CSA Grade 2 boots or equivalent
- industrial-quality leather gloves

- CSA-approved hard hat (where overhead hazards may exist)
- CSA Grade 2 boots or equivalent
- leg protection that is resistant to knife cuts

- CSA-approved hard hat (where overhead hazards may exist)
- boots that extend above the ankle; CSA Grade 2 or equivalent

When you are handling a

Chain saw

Clearing saw

Axe, bush axe, or machete

Shearing knife

Christmas tree shearer

When you are handling**Wear****Christmas tree baler**

- CSA-approved hard hat (operator only)
- hearing protectors
- face screen and/or safety goggles or safety glasses (operator only)
- CSA Grade 2 boots or equivalent

Loading Christmas trees

- CSA-approved hard hat
- CSA Grade 2 boots or equivalent

Dragging Christmas trees

- CSA-approved hard hat (where overhead hazards may exist)
- boots that extend above the ankle; CSA Grade 2 or equivalent

Mobile equipment

- CSA-approved hard hat
- hearing protectors
- face screen and/or safety goggles or safety glasses (if your cab is not fully enclosed)
- gloves or mitts with thick leather palms
- CSA Grade 2 boots or equivalent

—Animal

- CSA-approved hard hat
- CSA Grade 2 boots or equivalent

Mobile equipment (other than truck)

- hard hat (if your cab is not fully enclosed)
- hearing protectors when required by law
- CSA Grade 2 boots or equivalent

Truck

- CSA-approved hard hat (outside truck in designated area)
- CSA Grade 2 boots or equivalent

Planting and cruising

- CSA-approved hard hat (where overhead hazards may exist)
- leather or rubber footwear that extends above the ankle; CSA approval recommended

Wear

- CSA-approved hard hat (where overhead hazards may exist)
- hearing protectors on motorized equipment
- personal protective equipment recommended by chemical manufacturer (respirator, gloves, eye protection as specified)
- CSA Grade 2 boots or equivalent

- CSA-approved hard hat
- CSA Grade 2 boots or equivalent
- safety goggles or safety glasses with side protection
- gloves or mitts with thick leather palms
- hearing protection

- CSA-approved hard hat
- welding hood/shield
- welding gloves
- CSA Grade 2 boots or equivalent

- CSA-approved hard hat
- welding glasses
- welding gloves
- CSA Grade 2 boots or equivalent

- CSA-approved hard hat (where overhead hazards may exist)
- CSA Grade 2 boots or equivalent

- CSA-approved hard hat
- CSA Grade 2 boots or equivalent
- retro-reflective vest if working on or near roadways

When you are handling

Chemical application**Machine maintenance
—grinding,
hammering,
and chipping****—electric welding****—cutting and
gas welding****Supervision****Land survey crew**

Standards and Care Required

If your equipment and clothing are to protect you properly, they must meet certain standards and be kept in good repair.

Hard hat

- The hard hat you wear must be CSA approved. It must be highly visible (blaze orange is recommended). A white, silver, or dark-colour hard hat cannot be worn.
- Replace any hard hat whose shell or suspension has been damaged.
- Don't use fly repellent or oil on your hard hat because this will affect its protective quality.
- Don't leave your hard hat on the rear window shelf of a vehicle. Intense sunlight will affect its protective quality, and the hat may become a dangerous missile if the vehicle stops suddenly.

Safety footwear

- Footwear must be CSA Grade 1 or Grade 2 or of an equivalent standard. Factory-installed ballistic nylon is recommended, as are high-traction soles or the use of studs, caulks, or screws when conditions warrant.

Hearing protectors

If you are working in an area where the sound level is greater than 85 decibels, you must wear CSA Class A or B hearing protectors.

Muffs are more sanitary than earplugs. When using ear plugs, be sure to keep them clean and follow installation instructions on the package. Cotton wool and non-approved headphone sets cannot be used to replace proper hearing protectors.

Leg protection

Leg protection must be resistant to chain saw cuts. It must be approved by the Bureau de normalisation du Quebec (BNQ) or the equivalent. It should provide protection to both the front and back of the legs. It is recommended that the leg protection meet the requirements of category A or C devices as defined in BNQ standard CAN/BNQ 1923-450-M91 *Leg Protective Devices for Chain Saw Users*.

Gloves or mitts

Gloves or mitts must have thick leather palms to protect your hands if handling wire cable.

Equipment for chemical application

If you are unsure of the personal protective equipment required, refer to the material safety data sheet or contact the supplier for details **before** applying the chemical.

Supervising Employees

As a supervisor, employer, contractor, or owner you play a key role in ensuring the safety of your workers during forest operations. You should understand and act in accordance with the occupational health and safety acts and regulations, codes of practice in your province, and other applicable acts and/or regulations (see Appendix). The following are some of your responsibilities under the various acts.

Mobile equipment may be operated only by a trained operator or by someone who is being trained to operate the equipment.

Equipment training

No one may work without supervision on any machine unless that person

- has been properly trained and instructed in how the machine operates and the dangers associated with it
- has previously been supervised by someone who has a thorough knowledge of that machine and has had experience operating it
- is capable of safely operating the machine without supervision.

The operator of each piece of equipment must be able to recognize defects or unsafe conditions and carry out procedures to correct them.

Equipment operation

- A periodic visual check must be made of any employee working under hazardous conditions who might not be able to get immediate help in case of an injury. Checks must be made at intervals that are adequate for safety and that the employer and employee agree are practicable. If visual checks can not be made, other effective measures should be taken for securing help in the event of an emergency. The measures selected will depend on the hazard and the location of the work.
- A chain saw operator should not work alone. Another worker should be in the same operating area.
- Workers must not be given work that will endanger themselves or others.
- People under the influence of alcohol, drugs, or other substances that may affect their ability to work safely must not be allowed to enter or remain on the work site, because they could endanger their own health and safety and that of others.

Supervision

-
- Precautions should be taken if weather conditions create a hazard for workers.
 - First aid supplies and services must be available.
 - Generators, gas barrels, and the like must be located on mineral soil.
 - When building roads, no employee other than the operator may work closer than twice the height of the tallest tree to a bulldozer that is clearing a road right-of-way. In New Brunswick the standard is within 50 m of mobile equipment.

Employee responsibilities

Employees at work have responsibilities for health and safety and must co-operate with the employer and fellow employees to protect their own health and safety and that of other people at or near the workplace. (For more details, consult your provincial legislation.)



Housekeeping

- Garbage and litter must be removed from the site, for example, lunch wrappers, empty oil containers.
- Environmental standards must be complied with.

Reporting accidents

Provincial laws contain various requirements to report accidents. Readers should consult their provincial occupational health and safety agency and workers' compensation board or health, safety, and compensation commission.

In New Brunswick

Phone: (506) 453-2467 or 1-800-442-9776

Fax: (506) 453-7982

In Newfoundland and Labrador

Health and Safety Services

24-Hour Accident Reporting Line

Phone: (709) 729-4444

1-800-563-5471 (during working hours)

Fax: (709) 729-7982

Workplace Health, Safety and
Compensation Commission

Phone: (709) 778-1000

Toll-free 1-800-563-9000

Fax: (709) 778-1302

In Nova Scotia

Occupational Health and Safety Division

Phone: 1-800-952-2687 (toll-free in Nova Scotia)

Fax: (902) 424-5640

Workers' Compensation Board

Phone: (902) 491-8000

1-800-870-3331 (Mainland)

1-800-880-0003 (Cape Breton)

Fax: 491-8002 (Halifax—General)

563-0512 (Sydney—Accidents and General)

In Prince Edward Island

Occupational Health and Safety Division

Phone: (902) 368-5562; 628-7513 (after hours)

Toll-free: 1-800-237-5049

Fax: (902) 368-5696

Workers' Compensation Board

Phone: (902) 368-5680

Fax: (902) 368-5696

Chain Saws

With a little extra attention to the care and operation of chain saws, many injuries can be avoided.

When operating a chain saw you are required to have:

1. personal protective equipment (as described on page 11)
2. a chain saw with safety features (as described below)
3. felling devices
4. first aid available at the worksite (see page 65)
5. an approved fuel container (as described on page 26)
6. fire protection (as described on page 26).

Safety check

Chain saws used in forest operations must be equipped with certain safety features in working order: a front handle guard with a chain brake, a throttle control lockout, anti-vibration mounts, a safety chain, a rear hand guard, a chain catcher, a spark arrestor, a sprocket-nose guide bar, and an on/off switch. Before you start a chain saw check these features:

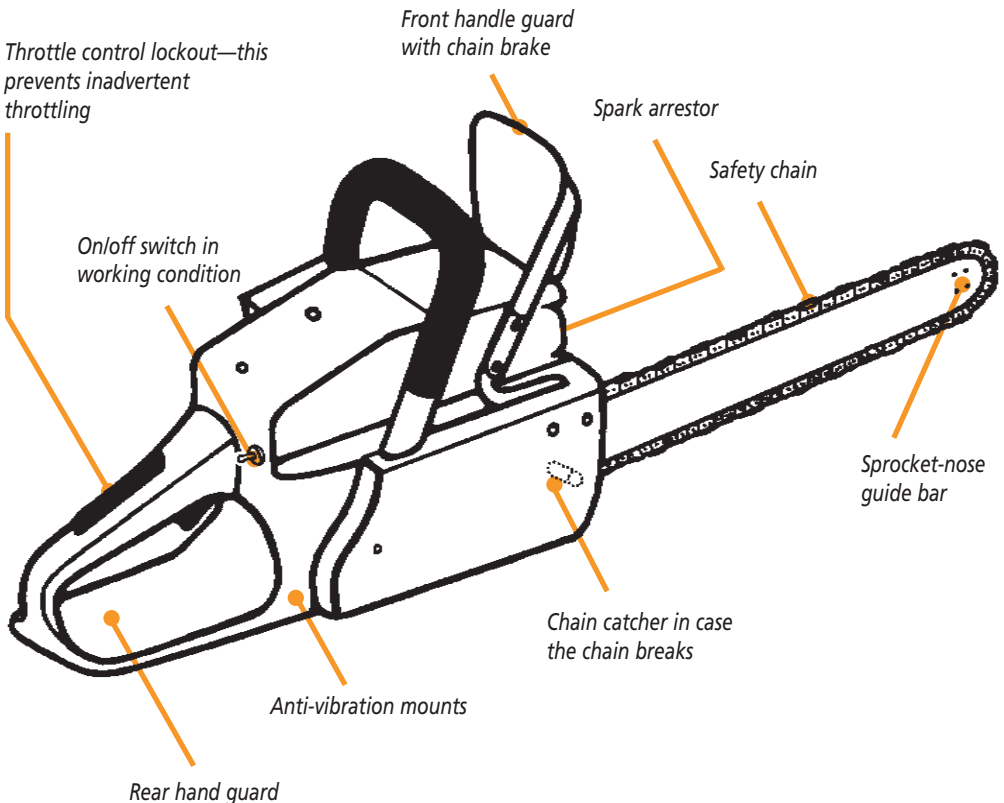

The chain brake must be able to prevent the chain from moving even though the throttle has been opened from idle to maximum. **Saws must not be operated unless this standard is met.**

Chain brake

The throttle must open only when the throttle control lockout is engaged.

Throttle control lockout

All rubber mounts or devices required to reduce chain saw vibration must be present and in good condition.

Anti-vibration mounts

The rear hand guard is installed under the rear handle. It is designed to protect the operator's hand if the chain breaks or leaves the guide bar.

Rear hand guard

The chain catcher is installed on the body of the saw below and ahead of the drive sprocket. It is designed to prevent the chain from whiplashing should the chain break or leave the guide bar.

Chain catcher

A 9- or 10-tooth sprocket-nose guide bar is recommended, depending on the chain pitch.

Guide bar

Muffler and spark arrestor devices must be in place year-round on all engines operated in the forest environment.

Spark arrestor

The sprocket-nose guide bar is intended to reduce the travel friction of the chain and may reduce the risk of kickback.

Sprocket-nose guide bar

Switches, as designed by the manufacturer, must be operational.

On/off switch

The saw chain must either include safety devices or be designed to prevent kickback.

Safety chain

Filing Techniques

Safety devices can be made ineffective with improper filing or poor maintenance. You can prevent this by using the following procedures:

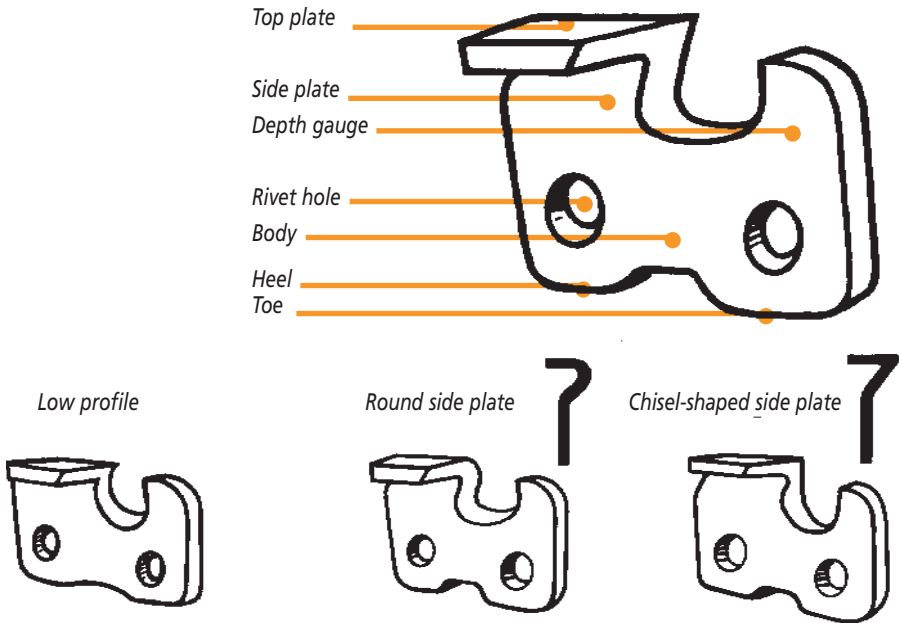

Keep at least 10 per cent of the file above the top plate of the cutting tooth when filing. Less than 10 per cent will cause you to file a hook in your chain.

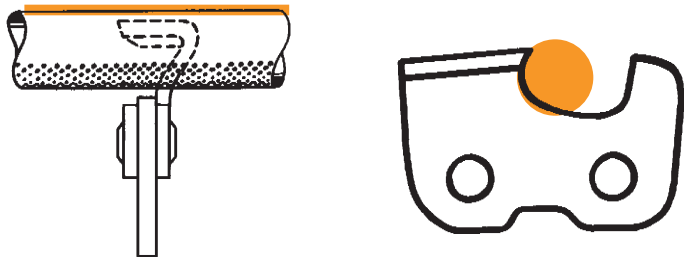

Troubleshooting

Cause The file was held too high, or it was too large.

Result The cutters won't feed into the wood resulting in slow cutting. Having to force chain to cut will cause excessive bottom wear.

Remedy File cutters to the recommended angle. Check filing methods with filing instructions. Check file size.

Backslope on side plate cutting edge

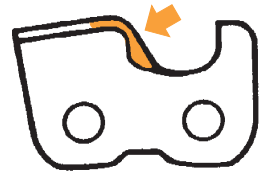

Cause The file was held too low or it was too small.

Result The chain grabs, causing rough cutting. The cutters dull quickly or won't hold a cutting edge.

Remedy File cutters to the recommended angle. Check filing method with filing instructions. Check file size.

Hook in side plate cutting edge

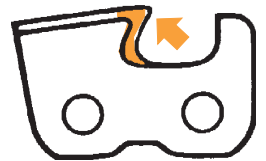

Follow the manufacturer's recommendations for filing. For example,

- Maintain the manufacturer's top plate cutting angle.
- Use the correct file size.
- Your depth gauge must not be lower than 0.0125 cm (0.005 in) from the manufacturer's specifications. If, for example, the manufacturer specified .0635 cm (0.025 in), your depth gauge should be no lower than .0760 cm (0.030 in).
- Use a filing gauge when filing the cutters and a depth-gauge tool when filing the depth gauges.
- Never file down or modify a safety link designed to prevent kickback.

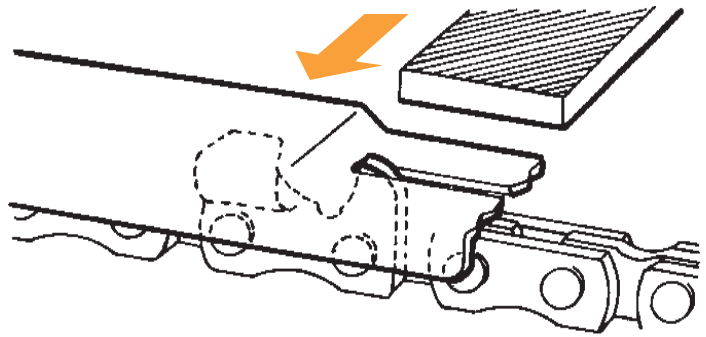

If the depth gauge protrudes, file to proper setting. Round off the leading edge of the depth gauge.

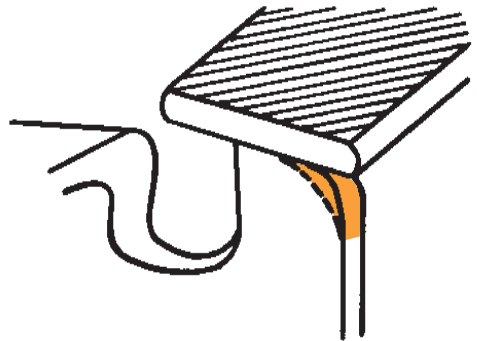

- Your chain should not be loose on the guide bar. For proper chain tension, make sure the tie straps of the chain are in contact with the bar rails on the bottom of the guide bar.

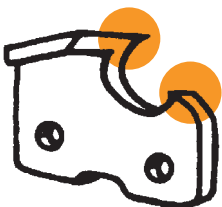

A chain with hooks filed in the cutters, with depth gauges filed too low, or with safety links filed down will grab and cause kickback. It will also cause excessive vibration and reduce the effectiveness of the anti-vibration features of the saw.

To operate a chain saw safely, read the saw's operating manual and keep the following in mind.

Operating a Chain Saw

The saw should be started in accordance with the operating manual. The following figure demonstrates typical starting procedures used, with the chain brake on to prevent the chain from turning.

To start

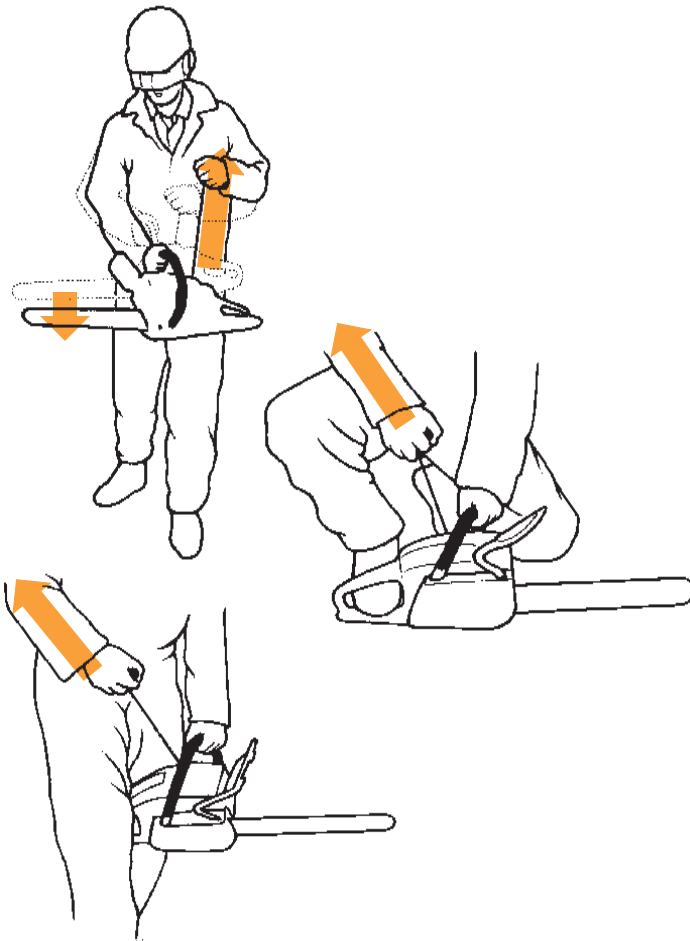

Note: In Newfoundland and Labrador, this is the only approved method for starting a chainsaw.

Position of hands

When operating a chain saw, hold the saw firmly with both hands. Place your left thumb under the front handle; this reduces the chance that the saw will be wrenched from your hands if a kickback occurs and may increase the chance of activating the chain brake.

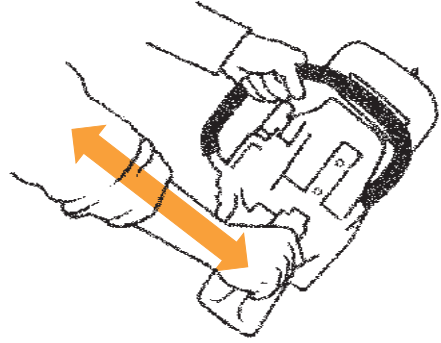
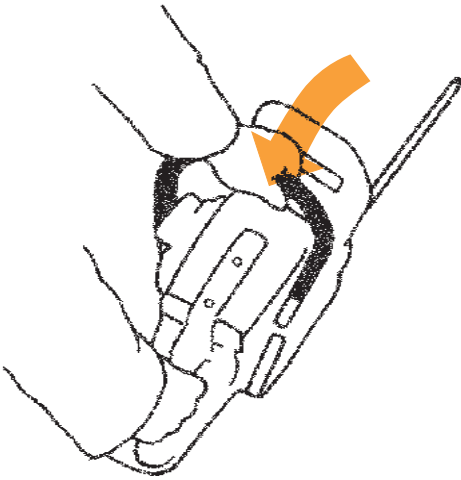

Keep your wrists straight. Bent wrists cause unnecessary muscle strain, and your arms will become tired.

Speed

Allow the saw to reach full speed before cutting, and maintain this speed while cutting.

Never use the upper half of the guide bar tip to limb, buck, or start a felling or boring cut. If you use this part of the bar, the cutters will hook the wood, and the saw will kick back. Kickback will be significantly reduced by using a low profile chain on a narrow nose bar (a 9- or 10-tooth sprocket-nose bar is recommended depending on the pitch of the chain).

Position of saw

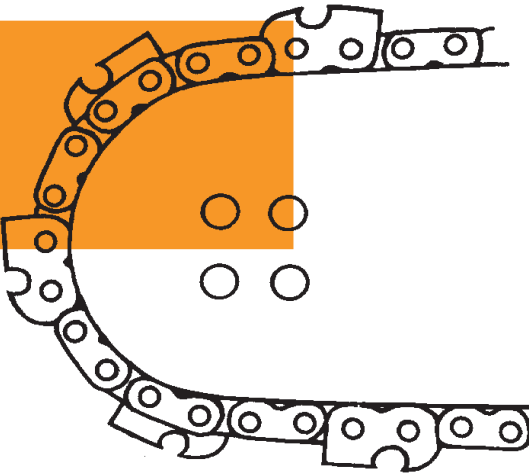

Do not operate the saw with the power head above shoulder height.

Make sure the saw is switched to the off position or the chain brake is engaged when you carry the saw. Don't carry it on your shoulder unless the chain is guarded and the guard is firmly secured to the saw.

Do not use components on your saw that are not specifically made for that chain saw.

Carrying the saw

Components

Refueling

Do not refuel the saw while the engine is running. Move the chain saw at least 3 m (10 ft) from the place where you refuelled before starting it. Do not overfill the fuel tank.

Storage and transportation of flammable material

Transport gasoline only in containers approved by the Underwriters Laboratories of Canada, Canadian Standards Association, or the provincial Fire Marshal or Commissioner.

Fire Marshal/Commissioner Office

New Brunswick

Phone: (506) 453-2393

Fax: (506) 453-5513

Newfoundland and Labrador

Phone: (709) 726-1050

Fax: (709) 729-2524

Nova Scotia

Phone: (902) 424-5721

Fax: (902) 424-3239

Prince Edward Island

Phone: (902) 368-4869

Fax: (902) 368-5526

Fire protection

- A chain saw operator must have a minimum of 227 mL (1 cup) of ABC fire extinguishing powder immediately available at the refueling site during the fire season.*
- Employers and employees must comply with fire protection requirements of the provincial Department of Natural Resources or other regulatory agencies. Information on fire season dates is available from your local office.
- The chain saw, clearing saw, and all other internal combustion engines must have spark arrestors.

* In New Brunswick the powder is required at all times.

* In Newfoundland and Labrador, the fire extinguisher (chemical) is required to be on the person, not at the refueling site.

With a little extra attention to the care and operation of the clearing saw, many injuries can be avoided.

Standards Required

When operating a clearing saw, you are required to have

- personal protective equipment (as described on p. 11)
- a clearing saw with safety features (as described below)
- first aid available at the worksite (p. 65)
- an approved fuel container (p. 26)
- fire protection (p.26)

Safety Check

Clearing saws used in forest operations must be equipped with certain safety features in working order:

- a throttle control lockout
- anti-vibration mounts
- blade guard
- on/off switch
- spark arrestor
- proper blade
- blade lock nut
- proper harness latch
- proper harness (note that adjustments to the harness should be made in accordance with manufacturer's specifications or instructions)

Note: Ensure that the clearing saw is turned off before performing maintenance.

The throttle control must not open when the throttle control lockout is engaged.

Throttle control lockout

All rubber mounts or devices required to reduce saw vibration must be present and in good condition.

Anti-vibration mounts

Switches, as designed by the manufacturer, must be operational.

On/off switch

Muffler and spark arrestor devices must be in place year-round on all engines operated in a forest environment.

Spark arrestor

Proper blade

Use only blades designed for the clearing saw in question. Inspect the blade each operating day, and replace it as soon as cracks or fractures appear.

Blade lock nut

Replace the blade lock nut as soon as it loses its locking power.

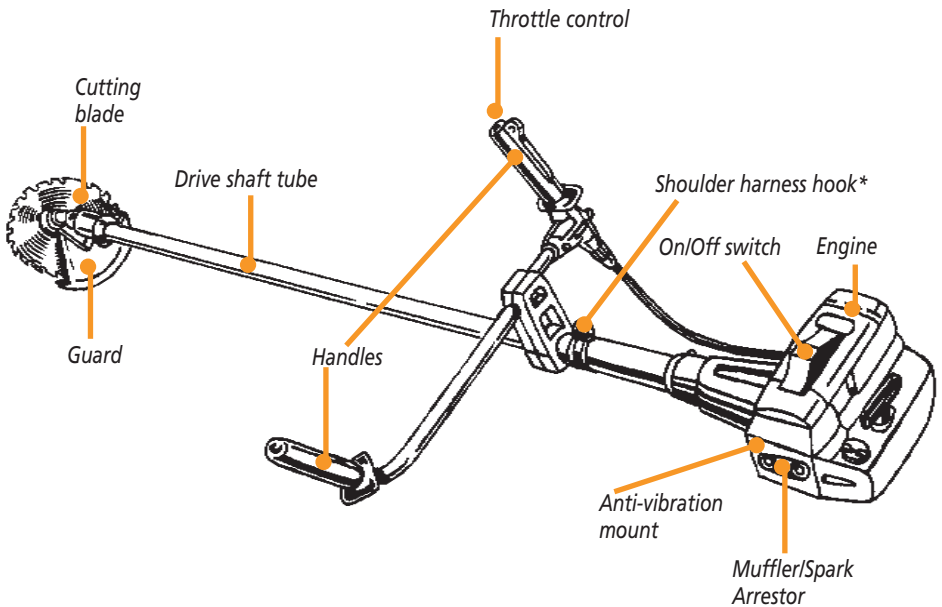

* Be sure to adjust the harness in accordance with the manufacturer's instructions.

Cutting Attachments

Clearing saws have a wide variety of cutting attachments. This versatility is at least partially responsible for the rapid expansion of this tool in non-forestry tasks by highway maintenance crews and landscape gardeners.

There are three basic types of clearing saw accessories, and each is designed for a particular application. These include

- **grass-cutting blades** for mowing matted grass, weeds, and light shrub growth

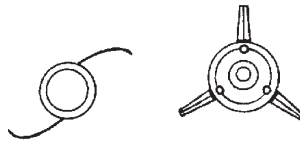

- **brush blades** for cutting and clearing undergrowth and brush; the additional weight provides the necessary chopping force to cut bushes and heavier shrub growth

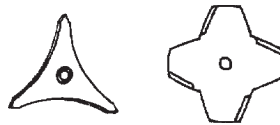

- **circular saw blades** for traditional silviculture applications like clearing woody bushes in a plantation, weeding, or precommercial thinning (PCT) a young forest stand; these come with various types of teeth, the most common being a chisel-tooth design.

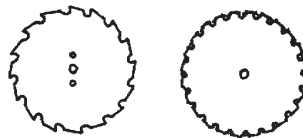

Sharpening the Blade

Sharpening is one of the most important aspects of using a clearing saw. The blade must be correctly sharpened so you can work effectively and avoid unnecessary wear on the blade and clearing saw.

Making a sharpening post

Although the saw can be held in several positions to sharpen the blade, the best approach is to make a sharpening post. A few quick cuts will provide a sturdy support at a comfortable working position. Find a tree 7–10 cm (3–4 in) in diameter. (Use a tree you are going to cut anyway.) To make a V-cut at waist height, grasp the drive shaft firmly with your left hand.

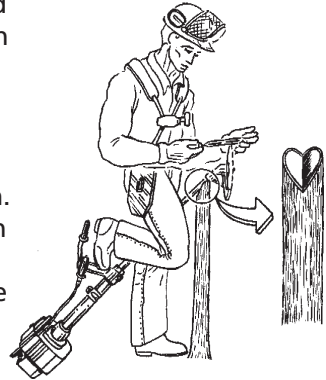

Think of the blade as the hour hand of a clock. Use the 5 o'clock position to make the first angled cut midway through the stem. Make the second angled cut to meet the first using the 9 o'clock position. Shut off the engine, unlatch the saw from your harness, and place the tube in the V-notch. Wedge a short stick between the blade and the guard to act as a friction brake and to allow you to use both hands when sharpening.

Filing angle

Consistency is as important when sharpening a clearing saw blade as it is when sharpening a chainsaw. All filing angles are to be the same (usually 15°) with the file held level or just below horizontal (e.g., 5°). Always read the manufacturer's instructions for any special sharpening requirements for the blade you are using.

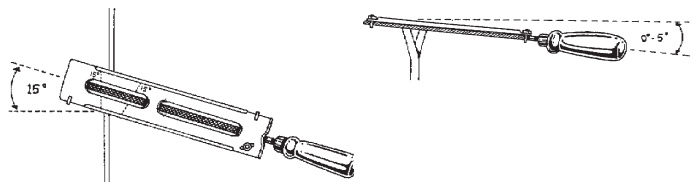

The actual file size for a specific blade is also recommended by the manufacturer and printed on the blade package. Most recommend a 5.5-mm (7/32-in) round file, together with the correct file holder and a handle. Ensure that the file holder is held firmly on top of the tooth.



After each stroke, ease up on the file as you draw it back. You will get a sharp edge on the tooth and avoid damaging the file. Sharpen the teeth on one side of the blade, then tilt the saw to do the other side. Working close to the ground, you can sometimes damage the blade by striking a rock. Severe damage will require more attention back at the repair shop or a new blade. Light damage can be corrected in the woods by the following procedure.

Use a flat file to file the top of all teeth gently, until only a small area of damage remains at the front tip of the tooth. Then, correct the filing angle with a round file. Ensure that all teeth are equal height after sharpening.



For the blade to cut with maximum speed and efficiency, it must be set to produce the desired kerf. Check the setting as part of your regular maintenance or if the blade has been damaged. For proper adjustment, twist the tooth tip out by pressing down and in on the setting tool. Most blade manufacturers recommend a setting of 1 mm.

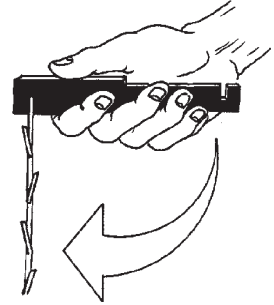
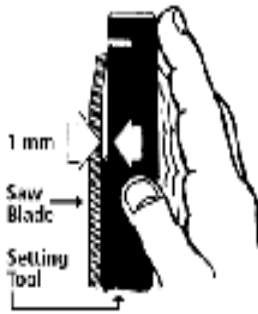

Avoid setting the teeth beyond the manufacturer's specifications and then readjusting. Unnecessary adjustments may weaken the tooth or cause breakage. Check the blade daily for cracks and/or broken teeth.

Cutting Techniques

The clearing saw is a special tool requiring special techniques and training. Professional instruction is worthwhile to eliminate any early frustrating situations that could easily have been corrected.

The cutting techniques used with the clearing saw may appear to be difficult. Actually, they can be easy, but it's a classic example of experience being the better teacher. Many clearing-saw operators say that you need a full season working with the saw to become comfortable with it. Most will also indicate that once you learn to use the saw properly, it is the best tool for small-diameter trees in various silviculture treatments in the right forest conditions.

Before beginning any cut, ensure that the saw is operating at full throttle and consider the blade position, tilt or angle of the blade, direction of approach, and stump height. Paying close attention to these items will make or break you as a good operator. The following techniques are for trees up to 6.3 cm (2.5 in).

Blade position

To describe the various techniques, we will refer to the blade as a clock face. The blade guard covers from 5 to 7 o'clock, so cuts can be made only from 8 to 4 o'clock. The illustration also shows the kickback zone, 12 to 2

o'clock. This zone should be avoided because it creates the greatest risk of having the saw suddenly kick out to the right side. Many trees have been accidentally wounded or cut down when the saw unexpectedly kicked. The kickback motion is powerful and can throw the operator off balance.

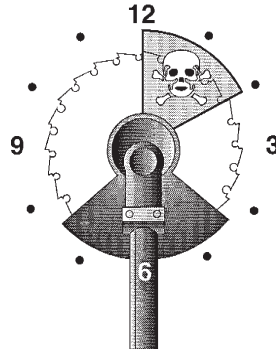

The circular blade moves in a counterclockwise direction. The right side of the blade from 12 to 4 o'clock pushes the base of the stem away from you so that the tree falls towards you. The left side of the blade from 8 to 12 o'clock pulls the base of the stem towards you so the tree falls away from you.

All felling is accomplished by deciding where you want the tree to fall and then choosing where to start cutting with the blade.

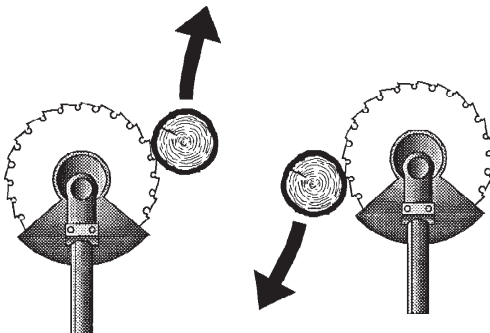

The tilt of the blade determines how long the stem stays on the blade and how far it moves from the stump. Stems cut using the 4 o'clock position and angled down to the right will fall off the stump fast. Stems cut using the 2 to 3 o'clock position, but angled up on the right, will stay on the blade while it is rotating and move away from you to the left. The safest control position when trying to protect the blade from hitting another object is 10 to 11 o'clock.

Tilt or angle of blade

Direction of approach

Whenever a cut is made, the direction you choose to “hit” the stem influences where it will go. This motion will help the stem go farther from the stump. Excessive force may damage the blade or saw. This “hit” motion should always be made with your legs and not your arms. At first, this method of moving your body with the saw instead of depending on your arms is not easy to do. It takes practice to develop, and it is best demonstrated by a skilled clearing-saw operator.



Stump height

The location of the cut is also important for directional felling. It may be necessary to change the height of the stump to influence where the stem will fall. Cuts made higher on the stem and at an angle will allow the stem to slide off the stump and fall further away. Note: For safety reasons, cut as low as possible.

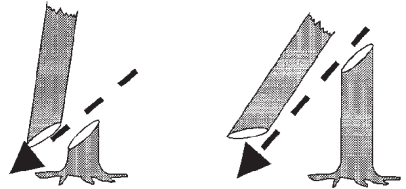

Directional felling

With the information presented, the following techniques demonstrate the three main felling directions of the clearing saw.

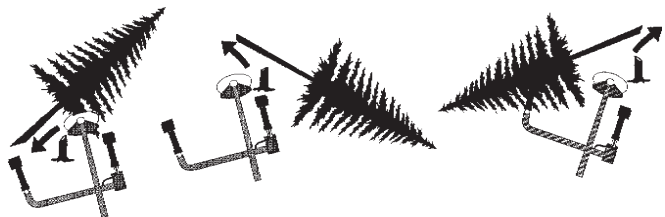

Like chain saws, all mobile equipment used in the forest industry must meet certain standards and be properly operated and maintained to reduce the chance of injuries.

Standards Required

Wherever required, rollover protective structures must meet the requirements set in the Canadian Standards Association B352-M1980 Code for Rollover Protective Structures (ROPS) or the Engineering Society for Advancing Mobility in Land Sea Air and Space SAE J1040 or J2194 and subsequent revisions.

Rollover requirements

Modifications made to a rollover protective structure must be certified by a professional engineer or have the written approval of the original manufacturer.

Modifications

Seat belts or other restraining devices must be used when mobile equipment is moving.

Seat belts

All operator protection on mobile equipment used for logging, silviculture, and forest road construction that is built by someone other than a manufacturer must be certified by a professional engineer.

Equipment not built by manufacturer

All debris such as twigs, leaves, etc., should be removed from around manifolds, transfer cases, and other areas that get hot and could cause a fire.

Debris

Head boards must be able to prevent objects from coming forward and hitting the cab.

Head boards

The climbing, walking, and working surfaces of mobile equipment must be non-skid. There must also be hand holds on each side of steps or ladders, and suitable foot and hand holds where someone might slip. Three-point contact while getting on and off a machine is a **must**.

Climbing, walking, and working surfaces

All Christmas tree balers with twine containers must be equipped with a locking or braking device on the twine can mechanism to prevent accidental rotation, unless work procedures can ensure equivalent worker protection.

Christmas tree balers

Fire protection

Employers and employees must comply with fire protection requirements of the provincial Department of Natural Resources or the appropriate regulatory agencies.

Brakes

Brakes must be able to stop the machine within a safe distance under all reasonably anticipated load/drag, speed, grade, and road conditions. They should at least be able to hold the machine stationary on a level road in second gear when the clutch is engaged at 50 per cent maximum-rated engine rpm or in accordance with the manufacturer's specifications.

Brakes should not be modified or changed from the manufacturer's design, because this will reduce their effectiveness.

Mobile equipment must have a parking brake that will prevent it from moving when fully loaded on an average grade of forest road without help from the engine, blade, or other attachment.

Steering

The steering mechanism must allow the operator to have full control over the direction in which the machine is moving.

Warning devices

All road-building equipment in a logging operation must have an automatic back-up device/alarm that automatically operates when the reverse gear is engaged.

All pulp and log trucks should have an automatic back-up device/alarm. If not, the driver must give a short blast on the horn before shifting into reverse.

In New Brunswick, automatic back-up devices/alarms are required on all powered mobile equipment.

When you operate mobile equipment, you are responsible for maintaining full control of it. Safe operation involves adherence to manufacturers' recommended maintenance and operational procedures.

Operating Mobile Equipment

Examine your equipment before each shift begins and at regular intervals. Report any defects or conditions that may affect its safe operation to your supervisor or employer.

Safety check

Fuel tanks in mobile equipment should never be filled while the engine is running, while anyone is smoking in or around the vehicle, or while a source of ignition is nearby.

Refueling

Never leave the controls of your machine unattended unless you make sure the machine cannot accidentally move in your absence. Set parking brakes and transmission locks; lower blades, buckets, or forks to the ground; lower grapples to the deck; and chock the wheels if necessary.

Unattended equipment

The swinging movement of a cab, load, counterweight, or other part of your mobile equipment can be a hazard to workers in the area. Never move your equipment when it will pose a hazard to another worker. No worker is allowed on the load, truck platform, or trailer when pulpwood, sawlogs, fuel wood, or similar products are being loaded on a truck.

Swinging equipment

Remove from your mobile equipment any unsecured material, tools, or equipment that could cause a worker to slip or trip or could be a fire hazard or danger if the machine upsets.

Excess items

Whenever possible, work up and down slopes rather than across them.

Slopes

Passengers

Only the operator of the machine may ride it, unless seat belts or other safe and secure facilities have been provided for other workers.

Vehicles used to transport workers must have a firmly secured seat for each passenger and have adequate ventilation in each enclosed area used to transport workers.

Transportation of flammable materials, tools, equipment

Flammable materials, or saws and other pieces of equipment that contain flammable material, may be transported in a vehicle designed to carry workers **only** if they are carried in approved containers and in an area of the vehicle that will protect the workers from vapours.

Materials, tools, or other equipment can be carried in the part of a vehicle where workers are riding **only** if these items are placed and secured so they will not injure anyone if an accident occurs.

Maintaining Mobile Equipment

Proper maintenance of your equipment will help assure a longer life and prevent injuries.

Modifications and repairs

All modifications, extensions, parts replacements, and repairs made to mobile equipment must maintain **at least** the same safety factor used in the equipment's original design.

Moving parts

Moving parts on mobile equipment that pose a hazard to the operator or other workers must be properly guarded.

Tire inflation

If the tire rims are equipped with lock rings, use a cage or any other device, such as a chain, to encase the tire before inflating it.

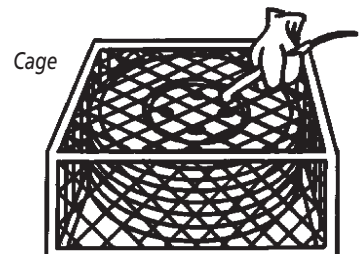
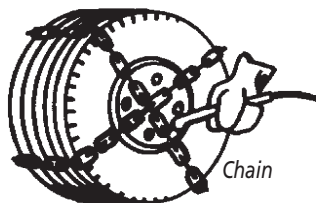

Use only methods approved by the **tire, wheel, and rim manufacturers** when mounting, inflating, and seating tubeless tires (ether, flammable, and petroleum-based products must not be used).

All hand tools must be kept in good condition. They should be used only for jobs for which they were intended, and only by workers who know how to use them properly.

Hand tools

Equipment must be blocked securely when it is being dismantled, altered, or repaired, because a worker may be endangered if the equipment collapses or moves.

Blocking

The blade, bucket, boom, cable, or other movable parts of the mobile equipment must not be used as a substitute for secure blocking.

Servicing, maintenance, or repair should be done only when the equipment is not being used **unless** the continued operation of the machine is essential to the repair process and the repairs can be done safely.

Servicing

Inspection, operation, repair, maintenance, and modification of mobile equipment must be carried out according to the manufacturer's instructions or according to good practice if there are no such instructions.

When working on the joint of an articulated machine, use a lock bar or similar device.

Correct Logging Procedures

Many injuries and deaths that occur in forest operations result from improper logging practices. There is a correct way to prelimb, fell, limb, and buck a tree. As a professional forest worker, you can protect your own safety and the safety of others by following correct logging practices.

Before Felling

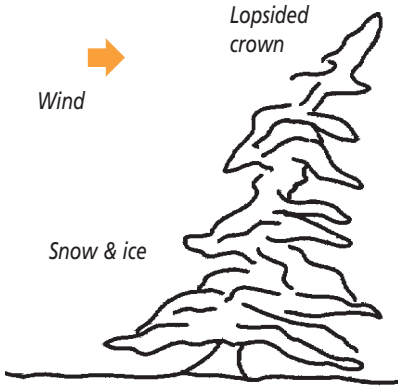

First, take a few minutes to assess the tree you plan to fall. A large sawlog tree may weigh a ton, so you must predict where it will be falling.

Some trees are more difficult to assess than others. Although trees generally grow upright, few stand perfectly straight. A lopsided crown, a broken top, dead limbs, prevailing winds, snow, and ice can all affect the direction a tree will fall.

Remove the brush and slash from the base of the tree before you start to fell it. This will ensure that brush and slash will not interfere with your saw or your footing, and you will have a clear escape route away from the tree.

Never work closer to another worker than twice the height of the tallest trees in the work area, unless that person is helping you.

In New Brunswick, no worker is allowed within 40 m of another worker.



Removing brush and slash from the base of a tree

Prelimbing a Standing Tree

Step 1

The first step is to cut back the ends of the branches so you can reach the trunk of the tree. Hold your chain saw parallel to your body. Then if the saw kicks back it will be directed away from your body.



Operate the throttle with your thumb.

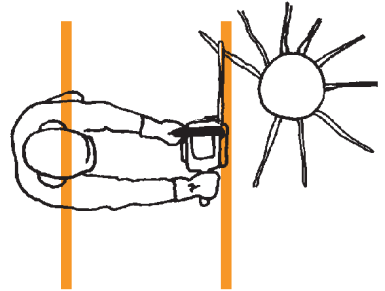

After you reach the trunk of the tree, hold your chain saw so the tree is between you and the guide bar. In this way, the tree will protect you if the saw kicks back.

Step 2

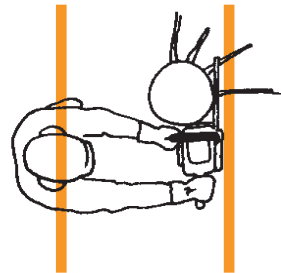

Felling

Many fatal logging injuries occur when workers are struck by falling trees. Improper felling procedures often cause this kind of accident. To reduce this risk, fell a tree in the following way:

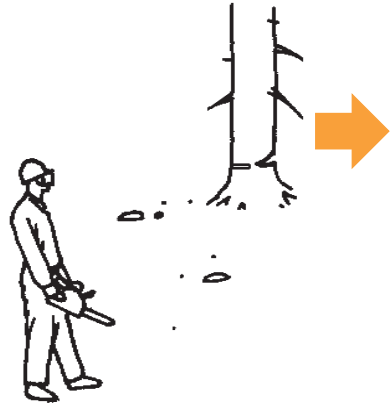
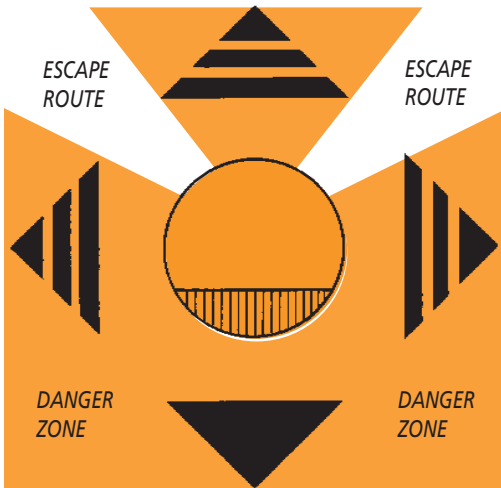

Felling principles

- Use a wedge, felling lever, or push pole to make sure the tree falls in the intended direction.
- Fell the tree away from you, downhill or across a slope if there is a chance that the tree may move downward towards you after it hits the ground.
- No one should push on a tree while a chain saw operator is cutting it.

The notch

- Both cuts should meet to form at least a 70° angle notch opening.
- Always make the upper notch cut first and then look into the kerf as you saw the lower cut. In this way, you can check that you do not saw too deeply into the trunk and cut the hinge.
- The depth of the notch should be at least one-fifth and no more than one-third of the tree diameter.

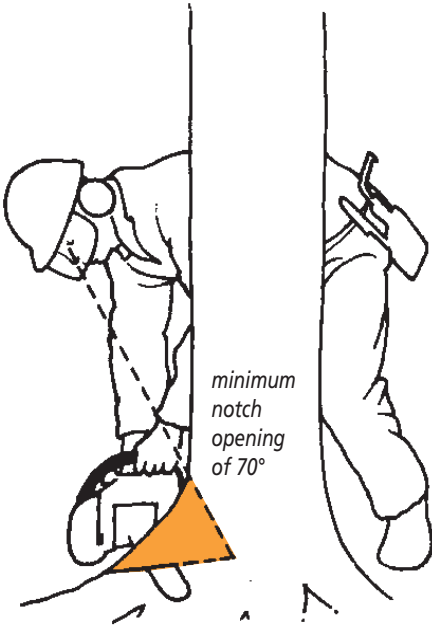

Always make the upper notch cut first and then look through the kerf as you saw the lower cut.

In this way you can make sure you do not saw too deeply into the trunk



Make the felling cut at right angles to the stem of the tree, level with or slightly above the notch.

Felling cut

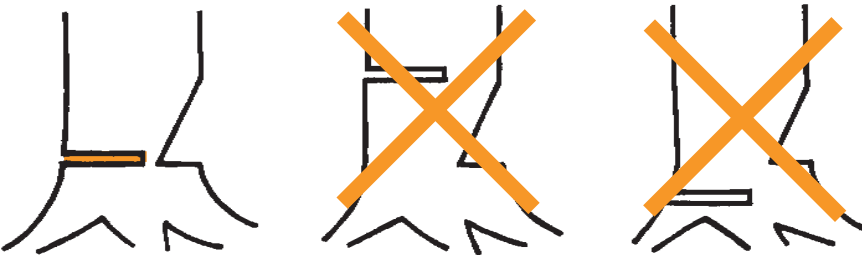

The hinge should be as thick as necessary to hold the tree to the stump until felling is completed (one-tenth of the tree diameter is recommended). If the tree is rotten, double the hinge width. For example, a 30-cm (12-in) tree should have a 3-cm (1.2-in) hinge; a 30-cm (12-in) rotten tree should have a 6-cm (2.4-in) hinge.

Hinge

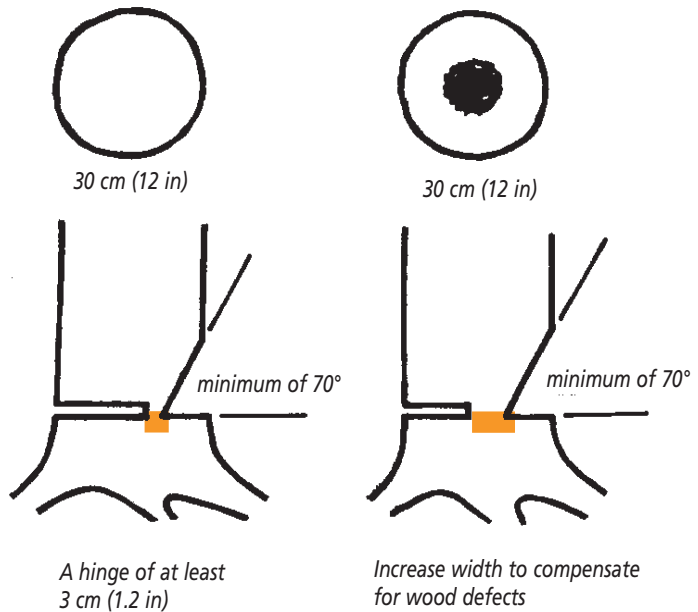

When the tree starts to fall

Move diagonally backward 1–5 m (3–16 ft) from the tree, depending on its size. When the butt kicks up it usually moves backwards or to the side.

Preventing barber chairs

A tree that is leaning heavily has tremendous tension directly behind the lean. As soon as you make a conventional felling cut you release this tension, and the tree will begin to fall. If too much wood is left holding the tree, this wood will split vertically, forming a barber chair, instead of breaking off horizontally. Barber chairs can also be caused by too small a notch.

To prevent a barber chair when cutting a tree that is leaning heavily:

1. Make a 45° bore into the centre of the tree while holding your saw in the normal felling cut position (Fig. 1).
2. Continue to bore through the tree, being careful you don't cut off the hinge (Fig. 2 & A).

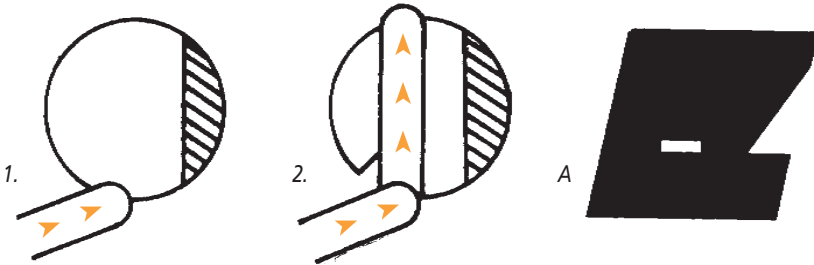

3. Cut towards the notch, leaving enough holding wood or hinge (Fig. 3 & B).
4. To cut the remaining wood, move the saw from the hinge towards the opposite side of the tree, leaving enough wood to prevent the tree from falling. If you are felling a tree that is larger in diameter than the length of your guide bar, bore cut from both sides (Fig. 4 & C).
5. Make the release cut **on the back side of the tree below the bore cut to allow the tree to fall** (Fig. 5 & D).

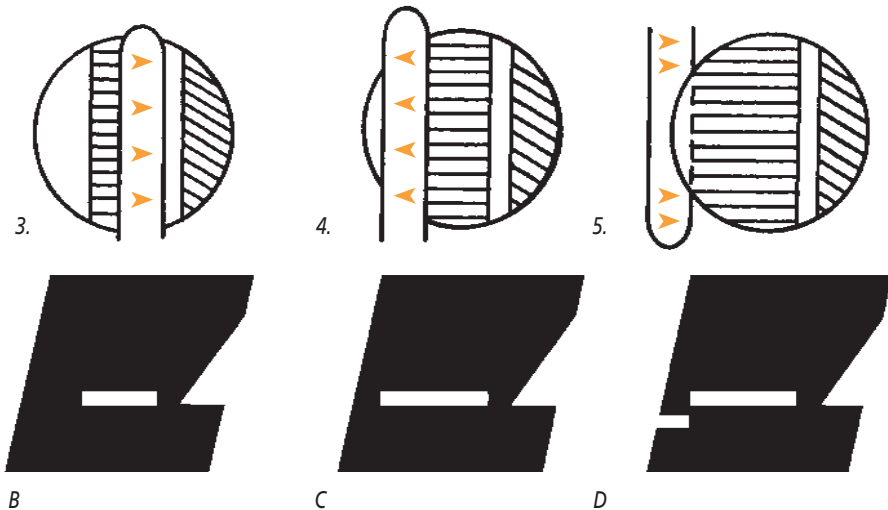

Partially cut or lodged trees

Never leave a partially cut tree standing. If a tree becomes lodged in another tree, work on it until it is on the ground. You can do this by using a skidder or forwarder to remove it, or by rolling the tree free, prying the butt end backwards, or bucking off short or merchantable pieces. **When you are bucking off pieces, be careful that the tree does not reverse its falling direction from the lodged position, and do not operate your chain saw guide bar above your shoulders.**

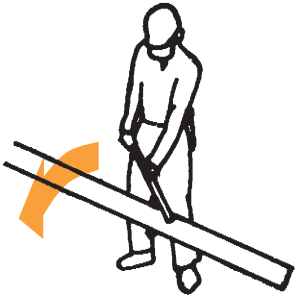

Rolling the tree

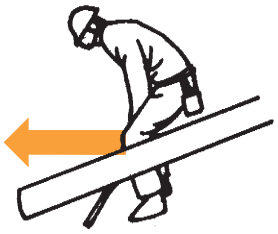

Prying the butt end backwards



Pulling the tree down with a skidder

- Lodged trees can be dangerous, so make sure you
- Do not work in the area where the tree is likely to fall.
 - Do not try to cut down the support tree.
 - Do not fell another tree across the lodged one.
 - Do not climb on the lodged tree.
 - Properly mark or flag the area to alert others of the hazard.



Forest workers **should not:**
— cut down a support tree



— work near a tree that could fall



— cut a tree so it will fall across a lodged tree

Dead or Dying Trees

A snag is a standing dead or dying tree and must be felled when it presents a hazard to any worker. Do not do other work in an area where a snag poses a threat.

Snags

Snags are very dangerous, so be careful when felling them. Fell a snag in the direction it is leaning. If you are using a wedge, do not drive it in, because this can create vibrations in the snag and cause the top to break off.

A cavity tree is a standing dead or dying tree with holes or the potential for holes that small wildlife may inhabit. Perching or nesting trees are also valuable habitats for wildlife. Cavity, perching, or nesting trees may be left standing if they are windfirm and present no hazard to workers. **However, if these trees present a hazard, they are to be felled.**

Cavity trees

Spring poles must be cut after a tree is felled and before it is limbed or bucked. To cut spring poles safely:

Cutting spring poles

- Release the tension by carefully cutting partway through the spring pole from the inside bend. Make a wide notch by using a series of shallow cuts near the base.

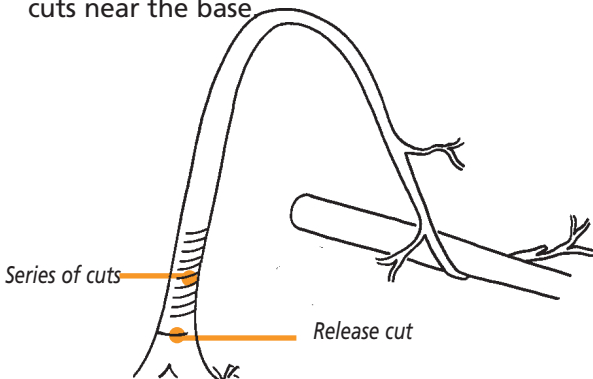

- The release cut (felling cut) can be made opposite and below the lowest inside cut.
- Do not cut the top of the stem until the tension is released at the base of the tree.

Limbing

Most of the professional chain saw operator's energy is used while limbing fallen trees. To reduce fatigue and lessen the chance of injury, limb a tree in the following way.

Before you begin

Before you begin limbing, and every time before you step forward, make sure the guide bar of your saw is on the opposite side of the tree from you.

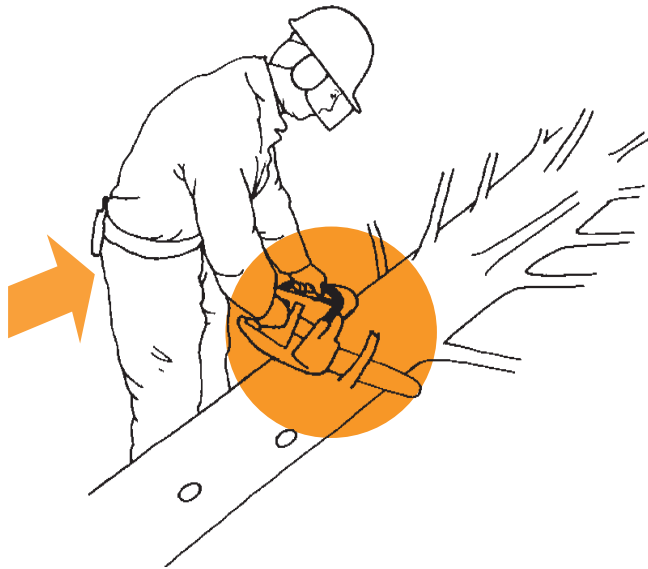

The saw should function as a lever

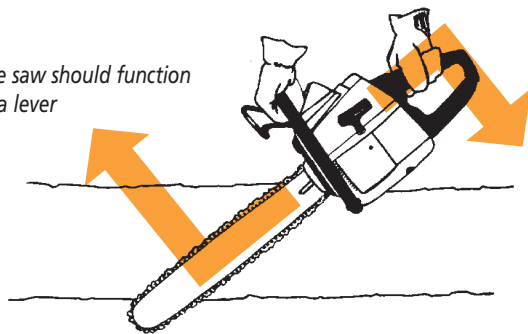

Operate your saw at a height between your knee and hip for best control. Stand firmly and limb close to you at all times. Do not put yourself off balance by stretching or overreaching. Keep the guide bar ahead of your right leg except when you are limbing the underside of a tree that is positioned between knee and hip level.

Position of saw

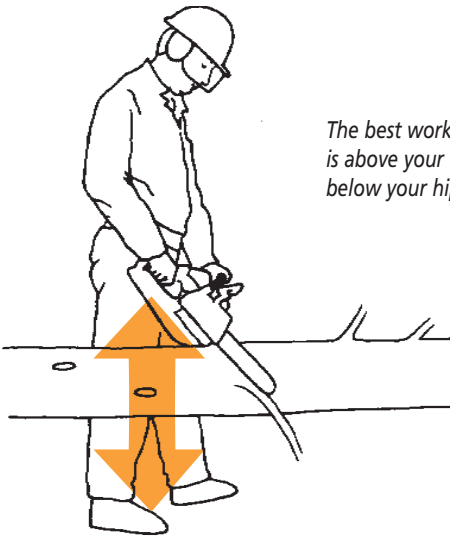

The best working height is above your knees and below your hips.

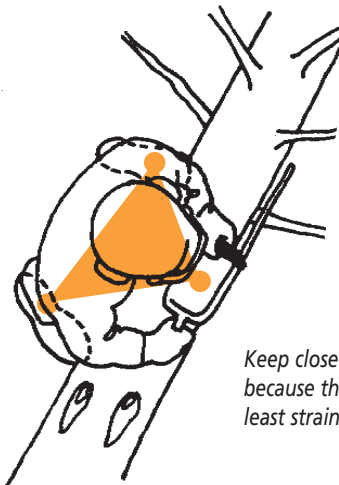

Keep close to the saw because this will put the least strain on your back.

Always support the saw on the trunk of the tree.
Do not limb with the tip of the guide bar, because the saw may kick back.

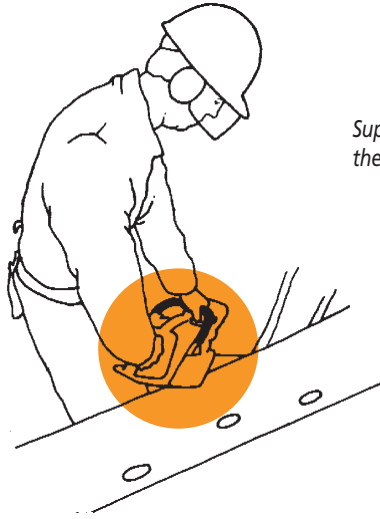

*Support the weight of
the saw on the trunk.*

*Do not delimb with the
upper tip of the guide bar.*

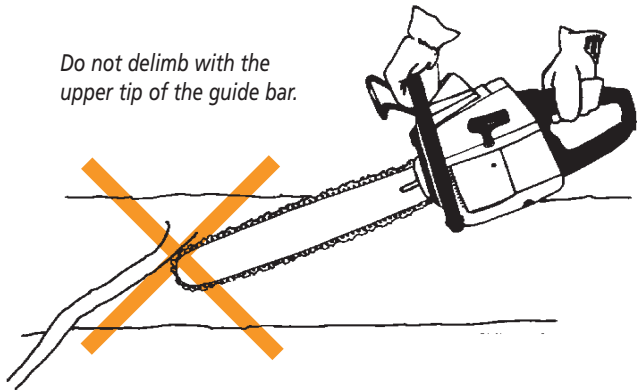

Beware

Never walk on the stem of a tree while it is being limbed.

Six-step limbing method

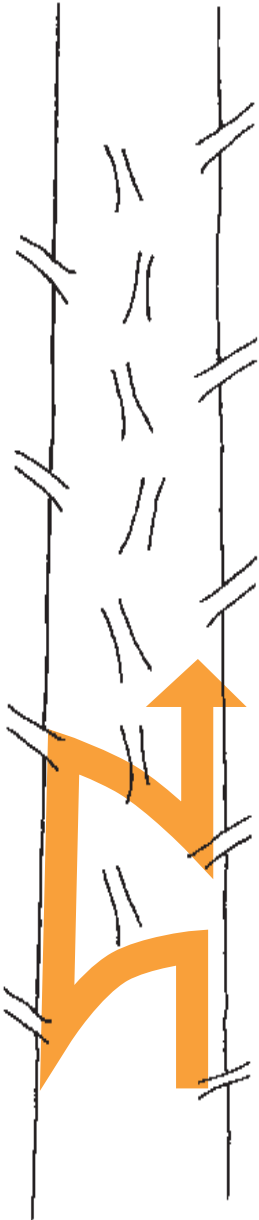

1.

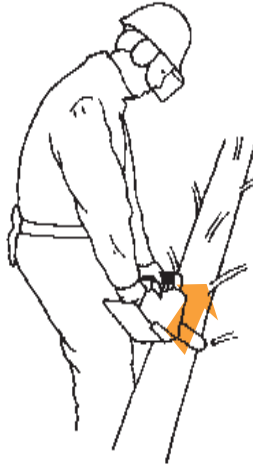

2.

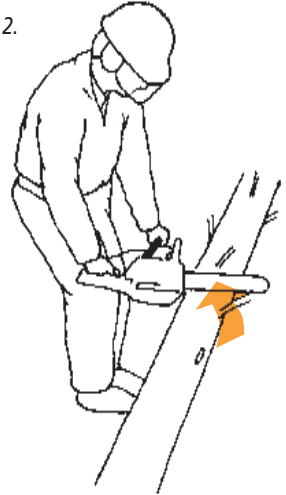

Fatigue and injuries can be reduced by using the following limbing method:

- 1. Always begin with the saw on the opposite side of the tree. Position your feet so they are pointed towards the top of the tree, and rest the saw body on the tree stem.*
- 2. Continue to rest the saw on the tree and rotate the saw towards your side, over the top of the tree stem.*
- 3. Pull the saw towards your side of the tree. Rest the saw body against your right leg and tree stem.*

4. Push the saw forward. Keep your knees bent and your back straight. Continue to support the saw with your leg. Stop pushing the saw forward when it becomes awkward to support the saw against your leg.

5. Turn the saw and use the top of the bar to remove the top limbs. Rest the saw on the tree stem.

6. To complete the sequence, use the bottom of the saw bar to remove limbs on the opposite side of the tree

You are now ready to begin again with the first step.

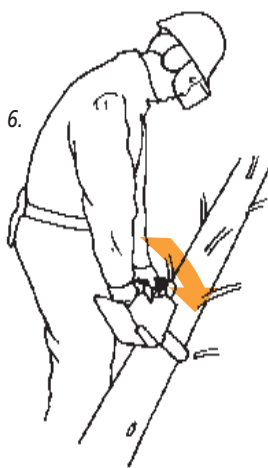
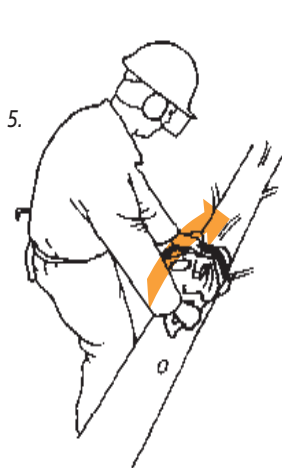
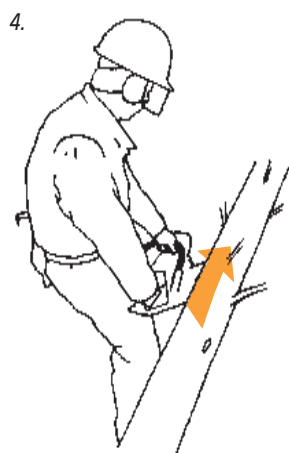
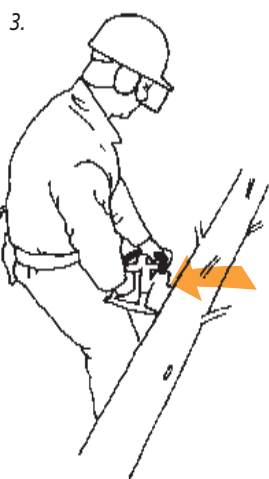
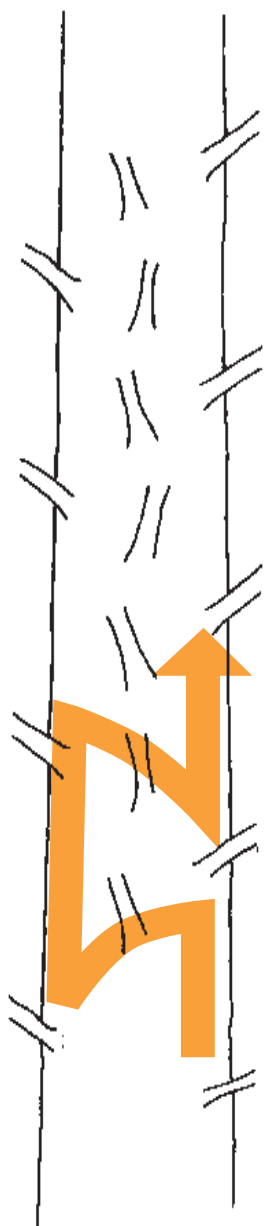

By following proper bucking procedures, you will reduce the likelihood of injuring yourself. Make sure you buck a tree in this way:

Bucking

- Stand inside the bend when bucking wood under tension.

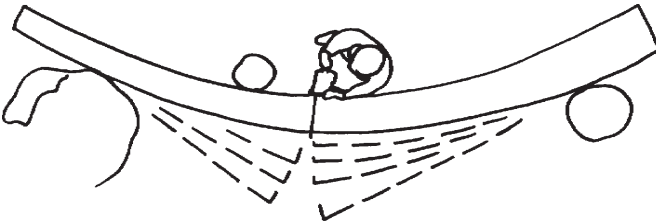

- Stand on the uphill side of pulpwood or logs you are bucking.
- Do not buck a log or top off a tree by using the upper side of the guide bar and pulling the saw towards you.
- Buck in the manner shown in the following illustration.

ESCAPE
ROUTE

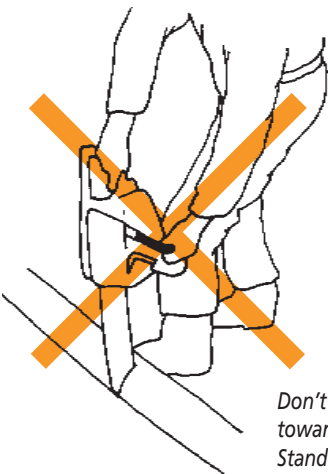

*Don't backcut, pulling the saw towards yourself.
Stand to one side of the cut and keep an escape route open.*

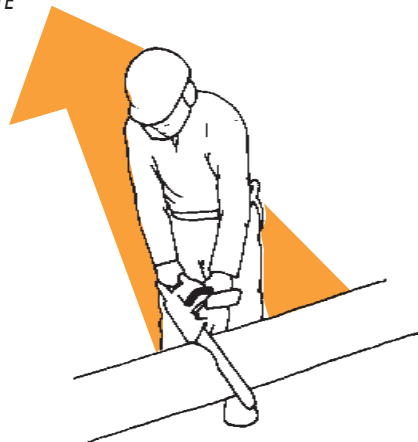

Yarding

Wood can be brought to roadside (yarded) by either skidding or using a forwarder. In either case, certain practices should be followed:

When yarding with animals

Make sure you remove the choker, twitching chain, or dog from the log before you buck or measure the wood.

When choking logs or trees

Chokers should be attached no farther than 1 m (3 ft) from the forward end of the tree.

Grappling or winching logs or trees

Stand a safe distance away from any logs or trees being grappled or winched. If you are operating the skidder or forwarder, ensure all other workers have moved to a safe distance before grappling or winching logs or trees.

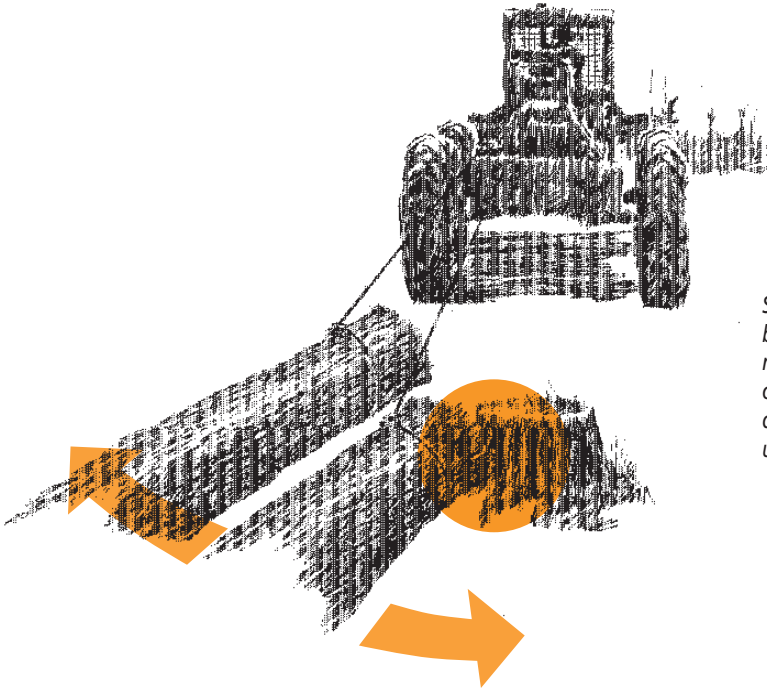

Stand clear. If a log being pulled by a machine strikes another object, it may move dangerously in an unanticipated direction.

Wire rope lines

Change wire rope lines (cables) if they become frayed or damaged.

Serious back injuries are caused by lifting and piling wood in the wrong way. To avoid injury:

Lifting Wood

- Roll, pull, balance, or lever wood to a pile. Make sure you keep your back straight and your knees bent.
- If the load is too large, get help.



Use a short lever to put less strain on your back

Use both hands.



A long lever will cause excessive and uneven strain on your back.

Keep your back straight and use your leg muscles.



If you are hauling logs by truck, you must follow the requirements of the Motor Vehicle Act and Regulations concerning the security of your load. Contact your local regulatory agency. For provincial information on load transportation contact: New Brunswick: Maintenance and Traffic Branch (506) 453-2600, Newfoundland and Labrador: Works, Services and Transportation, Motor Registration Division (709) 729-4640, Nova Scotia: Road Transport Inspection Division (902) 424-5973, Prince Edward Island: Highway Safety Division (800) 368-5200.

Hauling, Loading, and Piling Wood on Vehicles

Working near Power Lines

Power lines and electrical equipment can be deadly unless you know how to work around them. Before working near them, notify the people responsible for the lines or equipment so they can determine if working conditions are safe.

There are three main classes of power line: (1) transmission, (2) distribution, and (3) secondary and service lines. Transmission lines operate at voltages greater than 25,000 volts (25 kV). Distribution lines are lines that operate at a nominal circuit voltage of 750 to 25,000 volts (0.75–25 kV) measured phase to phase. Secondary and service lines operate at less than 750 volts. If you are working near power lines and do not know the voltage, contact the local electric utility office.

Planning your work

As part of your overall planning process, check for power lines in the area where you are going to work. Talk to the utility to assess hazards and plan safeguards. When planning operations, consider the following:

- Locate roads and trails to minimize crossing under power lines. Where crossing is required, ensure that there is adequate clearance for the equipment to be used. Travel areas under lines may have to be marked so operators can be guided to cross at appropriate locations.
- Locate landings and loading areas away from overhead lines.
- Mark “danger” trees that could fall into lines, so cutters can take appropriate precautions.

Keep the following in mind.

Ground clearance

Ground clearance under a power line may not be enough to allow you to drive a truck or mobile equipment underneath it. If you are working near a power line whose clearance is not clearly marked:

- Contact the local electric utility, which has the proper tools to measure ground clearance and can quickly establish the clearance for you.

-
- Remember that **ground clearance must be measured for overhead transmission and distribution lines.**
 - **Never** attempt to measure ground clearance on your own.
 - Make sure the ground clearance is checked and indicated with a highly visible marker before you cross under the line with a vehicle.

When your truck or mobile equipment will cross under a power line:

Crossing under power lines

- Cross under the line within 10–15 m (33–50 ft) of the structure supporting the line so your vehicle will have maximum clearance beneath overhead wires. If this is not possible, contact the electric utility.
- Cross only at designated spots.
- Don't travel directly under the wires when moving parallel to them.
- Maintain at least 3 m (10 ft) between overhead **transmission lines** and any extended part of your vehicle. **In Newfoundland and Labrador the required clearance distance is 5.5 m (18 ft).**

In New Brunswick, the required clearances are:

- 750 volts to 100,000 volts 3.6 m (12 ft)
- 100,000 volts to 250,000 volts 5.2 m (17 ft)
- 250,000 volts to 345,000 volts 6.1 m (20 ft)

In Nova Scotia, the required clearances are:

- 750 volts to 69,000 volts 3 m (10 ft)
 - 69,000 volts to 138,000 volts 5 m (16 ft, 5 in)
 - More than 138,000 volts 6 m (20 ft)
- Maintain at least 3 m (10 ft) between the lowest overhead **distribution** or **secondary lines** and any extended part of your vehicle.
 - If you are travelling under 120/240 volt service wires that run between a pole and a building, make sure your vehicle does not touch the wires.
 - Be aware that the sags in overhead wires change, and clearances may vary from time to time.

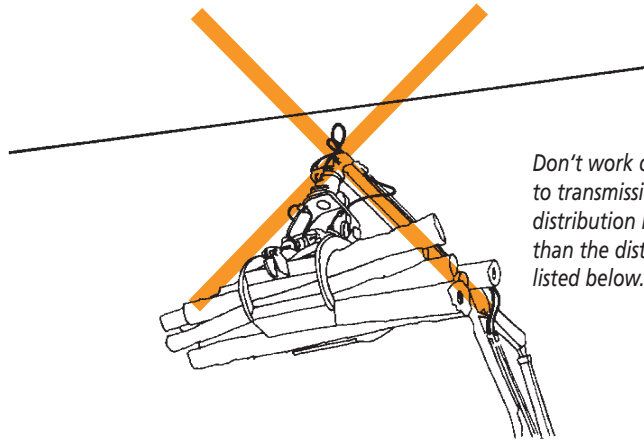

Don't work closer to transmission and distribution lines than the distances listed below.

Cutting near power lines

Cutting near power lines can be hazardous. To reduce the chance of injury, observe the following rules.

- Do not cut any tree that is within 3.0 m (10 ft) of a **transmission line** or that when felled **could pass within 3.0 m** (10 ft) of a transmission line. **In Newfoundland and Labrador the required clearance distance is 5.5 m (18 ft).**
- Do not cut any tree that is within 3.0 m (10 ft) of a **distribution line** or that when felled **could pass within 3.0 m** (10 ft) of the distribution line, unless the tree is at least 0.6 m (2 ft) shorter than the height of the distribution line. **In Newfoundland and Labrador the required clearance distance is 5.5 m (18 ft).**
- Do not cut any tree that may come into contact with a **secondary or service line** unless measures are taken to control the descent of the tree.
- Cutting trees closer than the above limits requires special training, should only be done by qualified personnel, and in some provinces requires certification.

Notify the local electric utility whenever you are working in an area where trees are within the above limits.

If, after you make your felling cut, you realize a tree is going to strike a power line:

Tree contact with power lines

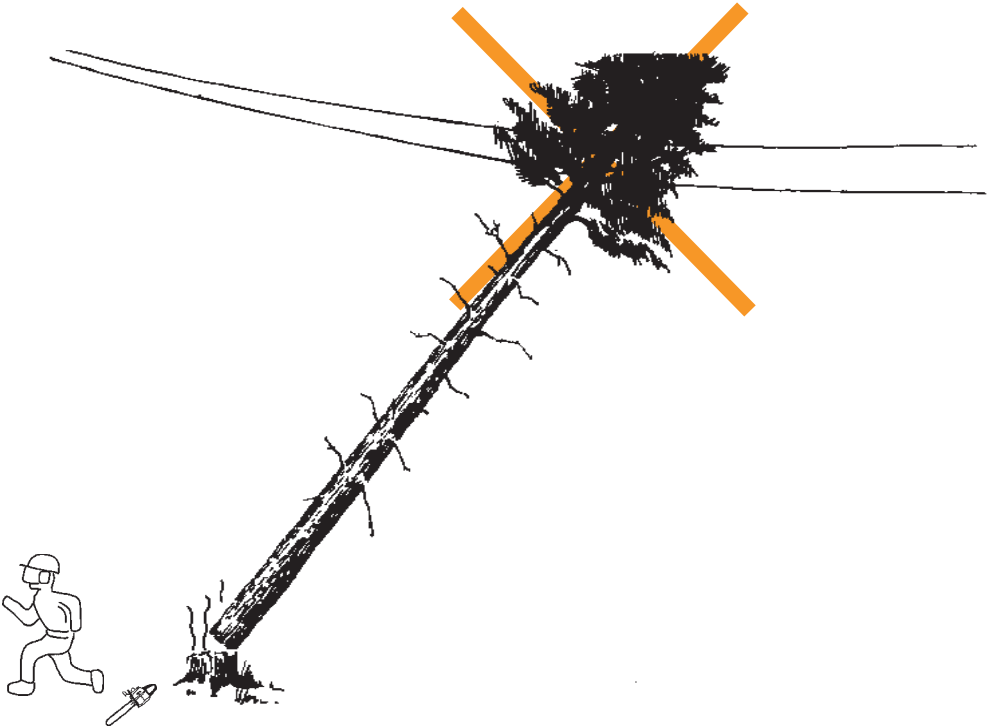

- Move quickly out of the work area.
- **Do not try to clear the tree or any cutting equipment, or return to the site to retrieve your saw if the tree is touching the line—this could be fatal.**
- Advise the local electric utility of the contact immediately, whether the tree contacts the line on the way to the ground, remains lodged on the line, or causes the wire to burn, break, and fall to the ground. (If the tree contacts the line on the way to the ground, the utility will want to check the wire for damage.)
- Post a guard about 15 m (50 ft) from the butt of a lodged tree to warn others of the danger.
- If you must leave the area unattended, mark or flag the area to alert others of the hazard.

Equipment contact with power lines

If you are driving a truck or mobile equipment that touches an overhead power line and remains in contact with it, **stay where you are** and warn others to stay away until the power has been disconnected or the contact broken. If possible, drive the vehicle away from the line.

You should only try to leave the vehicle if a fire breaks out or there is other danger. To leave an energized vehicle:

- Jump clear of the main frame, making sure you do not touch the tracks or tires, or any other part of the vehicle and the ground at the same time.
- Land with both feet close together and shuffle away from the vehicle until you are 15 m (50 ft) from it.
- Notify the electric utility of the contact.

Rescuing a co-worker

If a co-worker contacts an energized wire, tree, or vehicle and **remains in contact with it, do not attempt rescue**. You could receive a serious or fatal electrical shock.

If the person is thrown out of contact with the energized source, you can move the victim to a safe location and administer first aid.

How well woods roads are maintained and posted determines how safe they are.

Maintenance means

- maintaining woods roads in a condition that allows trucks and other mobile equipment to travel safely on them at all times
- installing bumpers at least 25 cm (10 in) high along the sides and entire length of the decking of bridges and of culverts over 1.5 m (5 ft) high (1.2 m (4 ft) in New Brunswick) that have a wooden deck
- felling snags that might eventually fall across a road or plug a ditch

Maintenance

Signs should be posted so they are highly visible

- at the intersection of a woods road and a public road designed for normal vehicle travel at 50 km/h or more
- 100 m (325 ft) from a bridge or other structure that requires vehicles to stop or slow down to pass and is not clearly visible
- 100 m (325 ft) from an obstruction used to prevent motorized vehicles from travelling on a particular road

Posting signs

All gates and cables must be clearly visible.

Each jurisdiction may have specific requirements that must be met when forestry operations are conducted from or near highways, streets, or other rights of way regularly travelled by the public

Temporary workplace traffic control

Contact the local authority.

New Brunswick Newfoundland and Labrador

Refer to the Traffic Central Manual for Roadway Work Operations. Contact the Traffic Engineer, Department of Work Services and Transportation.

Nova Scotia

This section is adopted under sub-section 4(3) of the Temporary Workplace Traffic Control Regulations, made pursuant to the Occupational Health and Safety Act as a procedure acceptable to the Director.

Prince Edward Island

Contact the local authority.

Public roads

Forestry operations conducted from or near highways, streets or their right of ways regularly travelled by the public must be signed as required by the provincial regulatory authority.

Forestry access roads

Forestry operations conducted from or near forestry roads must meet the Temporary Workplace Traffic Control criteria specified in this Code of Practice.

1. Application

- 1.1 This code applies to roads built or used primarily to facilitate forestry work activity or to transport forestry products.
- 1.2 This code applies to any forestry work activity including, but not limited to, harvesting, loading, road maintenance/repairs, silviculture, Christmas tree operations, surveying, or any other work that is intended to support forestry operations.

2. Definition

- 2.1 Work activity includes any active work site on the road surface or road shoulder.
 - 2.1.1 Road Class A, Road Class B are described as having a travel surface greater than 5.5 metres and have 1 1/2 to 2 lanes.
 - 2.1.2 Road Class C, Road Class D are described as having a travel surface less than 5.5 metres and have one lane with turnouts required to meet or pass other vehicles.
- 2.2 All signs specified for use must meet regulatory requirements.

3. General Requirements

- 3.1 All temporary workplace traffic control signs must be located off the travel lane(s).
- 3.2 All stationary vehicles and machines equipped with four-way flashers must use these lights when conducting work activity.
- 3.3 All stationary vehicles and machines equipped with revolving 360-degree flashing amber light(s) must use these when conducting work activity.
- 3.4 All road maintenance equipment must have revolving 360-degree flashing amber light(s) operating when conducting work activity.
- 3.5 All work activity involving stationary vehicles or machines shall be conducted to the extent reasonably practiceable at locations where the vehicle and machines are visible from both approaching directions.
- 3.6 Where the visibility of the work site is restricted from either approach direction so as to create a hazard, "Road Work" (TC-5) signs will be placed 100 metres from the work site on the approach direction where the visibility is restricted.

4. Where the Road Class is A and B:

- 4.1 Vehicles and machines shall use four-way flashers and a 360-degree flashing amber light(s), visible from both approaching directions.
- 4.2 "Road Work" (TC-5) signs must be located 100 metres on each side at the work site.
- 4.3 "Road Ends" (TC-43) or "Municipal Barrier" (TC-51) signs are required where conditions, or work activities at the work site are such that the road is not passable. Where practical the "Municipal Barrier" (TC-51) sign should be placed at the road entrance, or the intersection nearest the work site that would permit traffic to detour around the work site.

-
- 4.4 Where the work site is longer than 800 metres, “Person Working” signs are to be placed at 800-metre intervals along the road throughout the work site.
 - 4.5 All signs indicating work-site activity are to be removed at the end of the work day.
 - 4.6 Where roads are gated and secured to prohibit unauthorized entry, traffic control signs are not required where all authorized users know the location of the work site on the roadway.

Each forest operation must have first aid supplies and services, as required by the regulations in the province, available at all times, including

- adequate first aid supplies available at the work site
- a transportation plan
- someone at each work site who is certified in first aid and able to administer first aid
- a communications plan or remote location plan as required

As well, every chain saw operator must carry an approved pressure dressing when operating a chain saw. The need for a stretcher or backboard on site should be reviewed. Personal transport vehicles should be parked facing the most direct exit route from the site.

Personal Hygiene

Personal hygiene facilities including toilets and sanitation facilities must be considered and provided where required by regulation.

backcutting	the dangerous and unacceptable practice of dragging the saw back towards your body, using the top of the bar
baler, Christmas tree	motorized machine for wrapping Christmas trees with mesh or rope
barber chair	formed by a tree that splits up the stem from the base during the felling
boring cut	a cut into a tree started with the bottom tip of the guide bar
bridge	buttress and stringers 1.8 m (6 ft) or more in length
brush	limbs and tops cut from the stems of trees
buck	to cut a tree into logs after it is felled
bumper	the low curb on a bridge
cavity tree	a standing dead or dying tree greater than 30 cm (12 in) in diameter at chest height, with holes or potential for holes suitable for wildlife habitat, that does not create a hazard to workers
chain saw	any hand-held portable motorized saw used in a forest operation
choker	a cable or chain with a sliding device that enables the cable to self-tighten around the material being hauled
choking	attaching a choker
clearing saw	motorized portable saw with a circular cutting blade or attachment connected to an extended shaft
culvert	a structure less than 1.8 m (6 ft) in width used to direct water under a roadbed
dog	a device attached to trees or parts of trees to allow them to be hauled

a vehicle in contact with a power line	energized vehicle
a process whereby a standing tree is mechanically separated from its base, allowing it to fall to the ground	felling
a final cut made directly opposite the notch to allow the tree to fall	felling cut
burning of combustible solids such as wood or paper	fire, Class A
burning of combustible liquids such as gasoline or diesel fuel	fire, Class B
electrical fires	fire, Class C
logging equipment used to carry trees or parts of trees to roadside	forwarder
the distance between an overhead electrical line and the ground	ground clearance
the part of a chain saw on which the saw's chain travels	guide bar
the portion of a tree between notch and felling cut that allows control of the tree during felling	hinge
a saw cut made into a tree	kerf
the sudden upward or sideways movement of a chain or clearing saw	kickback
the removal of limbs from the stem of a tree	limbing
a split-metal band used to secure a two-piece tire rim	lock ring
a tree that has been cut and has not fallen completely to the ground because it has become lodged on another tree or other object	lodged tree
any piece of pulpwood, sawlog, pitprop, pole, post, tie, fuel wood, or similar product of a tree	log

mineral soil	ground free of combustible soil and debris
mobile equipment	self-propelled machinery used in a logging operation, excluding trucks
notch	a wedge or section of a tree base that is sawn out to control the direction the tree will fall
overhead distribution line	a power line that distributes electricity within communities and surrounding areas and has a capacity of 25,000 volts or less
overhead transmission line	a power line that transmits electricity to various parts of the province and has a capacity greater than 25,000 volts
prelimbing	the removal of lower limbs from the stem of a standing tree to create easier access to its base
rollover protective structure	a cab or roll bar to protect the operator of mobile equipment in case the equipment rolls over
safety footwear CSA Grade 1	footwear that will withstand a toe impact of 125 joules
safety footwear, CSA Grade 2	footwear that will withstand a toe impact of 90 joules
service wire	a power line that services homes and businesses from the distribution system
shearing knife	a long-bladed knife with varied handle lengths, used to shear (shape) trees
skidder	an animal-powered or mechanized piece of equipment used to skid or drag whole trees or parts of trees
slash	portion of tree cut and left on the ground

a standing dead or dying tree or part of a tree that presents a hazard to workers	snag
a standing tree with the top stem trapped, creating a bow-like structure	spring pole
the main body of a tree from base to top, the trunk	stem
like a choker but without a slider	twitching chain
truck or mobile equipment	vehicle
pulling a load towards a machine, using a cable	winching
a road through a forested area, other than a municipal or provincial highway, that may be used to transport forest products by motorized vehicle	woods road
an area where logging operations are being carried on	work area
dragging trees or parts of trees to a roadside	yarding

Occupational Safety and Health

Legislative Framework

Each year in the Atlantic Provinces, workplace accidents and disease directly cost well over \$100 million and directly affect thousands of workers who are injured or ill. These statistics do not consider the thousands more workers and many more millions of dollars that are indirectly related to workplace incidents.

Current occupational health and safety acts are a major step towards reducing accidents and illnesses in the workplaces in the Atlantic Provinces. This is achieved by providing rights and responsibilities to employees, employers, and others in the workplace.

An important part of each occupational health and safety agency's efforts to provide reasonable and practical rules to meet the needs of their clients is to consult with employers, unions, government, and public interest groups and make recommendations on matters related to occupational health and safety.

The objective in regard to occupational health and safety is to promote comprehensive and practical preventive strategies to improve the working environment.

This approach to workplace health and safety provides for consultation and an opportunity to educate workplace parties about hazards in their workplaces. The legislation and programs go beyond providing rights and responsibilities to the parties by helping them develop safety and health systems in their workplaces.

The legislation and programs provide support for employers, employees, and others through education, promotion, facilitation, and enforcement of the legislation.

The following information is available to employers, employees, and other interested parties as background to understand the legislative framework.

The occupational health and safety acts provide for the promotion, co-ordination, administration, and enforcement of occupational safety and health.

The Acts

The acts place certain duties on a number of workplace parties, that can include employers, employees, self-employed persons, constructors, contractors, professionals, owners, suppliers, and providers of occupational health and safety services.

They also place emphasis on the prevention of accidents, injury, and disease through an internal responsibility system that promotes co-operation and involves the workplace parties in workplace health and safety practices.

The Occupational Health and Safety Acts are organized around five basic elements:

- Prevention—Education, policies and procedures create a safe and healthy workplace in which, to the greatest extent possible, potential hazards are anticipated and prevented before they arise.
- Internal responsibility—Each workplace is responsible for implementing an effective system for employer, employees, and others to co-operatively
 - identify health and safety problems in the workplace
 - identify and implement potential solutions
 - provide an internal audit of the workplace's compliance with health and safety requirements

-
- External support—A system external to the workplace to support the internal responsibility system within the workplace and monitor its effectiveness.
 - Enforcement—Legal sanctions may be applied to parties who fail to comply with the requirements of the acts.
 - Response to changing needs—Through policy and leadership capacity government and affected parties evaluate and respond to the needs of the workplace.

Regulations

In addition, the broad duties established by the acts are supported by a further tier of laws, commonly referred to as regulations, together with lower tiers of codes of practice and guidelines.

Regulations have the effect of spelling out the specific requirements of the legislation and may prescribe specific standards or performance. Regulations may also have general application or apply to a particular hazard or a particular type of work or workplace.

Specification regulations prescribe the minimum standards that will be considered acceptable. Performance regulations specify the objective and allow a variety of approaches to meeting the objective. Both approaches to regulation are used separately and in combination.

Codes of Practice

A code of practice is a document prepared to provide practical advice on preventive strategies, for a specific hazard or in a specific workplace, or a practical means of achieving compliance with occupational health and safety in legislation.

A code of practice may contain explanatory information in addition to specific advice on activities. The preventive strategies outlined in a code of practice may not represent the only acceptable means of achieving the standard to which the code refers.

A code of practice does not always have the same legal force as a regulation but in some cases can be made so, through enforcement by the occupational safety and health agency.

The next tier comes in the form of guidelines. A guideline is an explanatory document providing detailed information on the requirements of legislation, regulations, standards, codes of practice, or matters relating to occupational health and safety.

Guidelines

The guideline, although not intended as a legally binding instrument, is based on the regulatory framework and provides information on acceptable practices to achieve regulatory compliance. In many cases the guideline will provide interpretation of the intent of the legislation and describe the rationale used in its development. The guideline may, in addition, describe proactive programs or services that exceed the regulatory and legislative requirements.

Each province has specific legislation that applies to forestry operations. To assist in the identification of the frequently cited legislation the following list has been prepared for each province.

Although we have attempted to be accurate, the listing may not be complete, and you should contact your provincial regulator.

New Brunswick

1. Selected regulations made pursuant to the Occupational Health and Safety Act. *Statutes of New Brunswick* 1995.
 - Occupational Health and Safety Act
 - General Regulations
 - Administration Regulations
 - Code of Practice for Working with Material Containing Asbestos
 - Code of Practice for Working Alone
 - Workplace Hazardous Materials Information System Regulations
2. Additional legislation available
 - Labour Standards Code
 - Workplace Health Safety and Compensation Commission Act
3. Transportation of Dangerous Goods Regulations
New Brunswick
4. New Brunswick Environmental Protection Act
5. New Brunswick Motor Vehicle Act and Regulations

Newfoundland and Labrador

1. Selected regulations made pursuant to the Occupational Health and Safety Act. *Statutes of Newfoundland*, March 10, 1999.
 - Occupational Health and Safety Act
 - Occupational Health and Safety Regulations
 - First Aid Regulations
 - Occupational Health and Safety (Electrical and Fisheries Advisory Committees) Regulations

-
- Workplace Hazardous Materials Information System Regulations
 - Newfoundland and Labrador Petroleum Drilling Regulations
 - Electrical Regulations
 - Asbestos Abatement Code of Practice
 - Newfoundland and Labrador Offshore Petroleum Drilling Regulations
2. Additional legislation available
 - Labour Standards Code
 - Radiation Health and Safety Act and Regulations
 - Smoke-Free Environment Act
 3. Transportation of Dangerous Goods Regulations Newfoundland and Labrador
 4. Newfoundland and Labrador Environmental Protection Act
 5. Newfoundland and Labrador Motor Vehicle Act and Regulations
1. Selected regulations made pursuant to the Occupational Health and Safety Act. *Statutes of Nova Scotia* 1996, Chapter 7.
 - Occupational Safety General Regulations
 - Occupational Health Regulations
 - First Aid Regulations
 - Disclosure of Information Regulations
 - Workplace Hazardous Materials Information System Regulations
 - General Blasting Regulations
 - Temporary Workplace Traffic Control Regulations
 - Fall Protection and Scaffolding Regulations
 - Appeal Panel Regulations
 2. Additional legislation available
 - Labour Standards Code
 - Workers' Compensation Act

Nova Scotia

-
3. Nova Scotia Environment Act and Regulations
 4. Nova Scotia Motor Vehicle Act and Regulations
 5. Nova Scotia Forests Act

Prince Edward Island

1. Selected regulations made pursuant to the Occupational Health and Safety Act. *Statutes of Prince Edward Island*, December 2000.
 - Occupational Health and Safety Act
 - Occupational Health and Safety Regulations
 - Workplace Hazardous Materials Information System Regulations
2. Additional legislation available
 - Labour Standards Code
 - Workers' Compensation Act
3. Transportation of Dangerous Goods Regulations
Prince Edward Island
4. Prince Edward Island Environmental Protection Act
5. Prince Edward Island Highway Act and Regulations

