



PROC 5071: Process Equipment Design I

Filtration

Salim Ahmed

1 Filtration Basics

1.1 Day to day examples

- Think about how a **vacuum cleaner** works.
- Layers of special fabrics create two sides of the cleaner. A fan sucks air from the inner side and thus create a pressure difference between the inner and the outer side. Air from the outer side flow to the other side; however, the fabric layers do not allow particles larger than some size.
- Another example is the sink strainer. While it allows water and smaller particles to go through, larger particles are retained. The flow here is due to gravity.

1.2 Definitions and terminologies

- **Filtration**: a separation process where **solid particles in a fluid are mechanically removed by using a porous medium**
- **Slurry**: the suspension of solid and liquid to be filtered
- **Filter medium**: the porous medium used to retain the solids
- **Filter cake**: the accumulated solids on the filter
- **Filtrate**: the clear liquid passing through the filter

1.3 Products of filtration

- The **desired product** of filtration may be either the filtrate or the separated solid.
- Sometimes neither of those may be desired; e.g. for waste materials it may be required to dispose solid and liquid waste separately.

1.4 Types of filter based on force

Filtration happens due to the pressure difference across the medium which can be achieved in different ways

- Pressure filter: pump the slurry to the filter
- Vacuum filter: a vacuum is created on the filtrate side
- Gravity filter: a head of slurry is maintained over the medium
- Centrifugal filter: a centrifugal force is created on the slurry side

1.5 Modes of operation

- Continuous filtration
 - Filter cake is continuously removed
 - Operations do not need to be stopped for collecting the cake
- Discontinuous filtration
 - Filter cake is can be removed only after filtration is stopped

1.6 Types of filter based on separation mechanism

- Cake filter

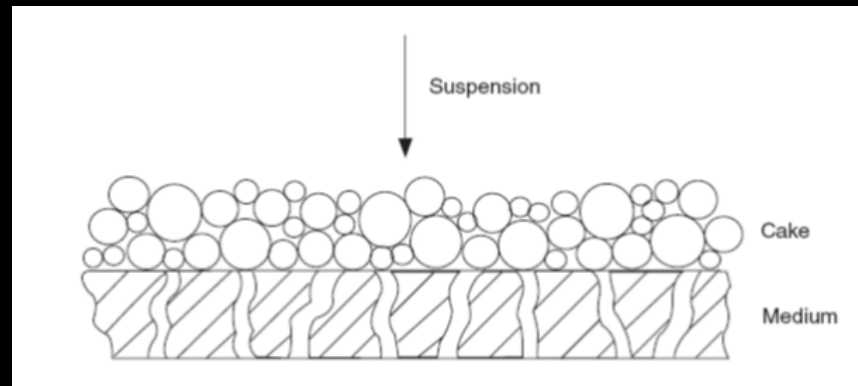

Figure 1: Schematic of cake filtration.

- In the case of cake filter, at the beginning of filtration some **solid particles enter the pores of the medium and are immobilized.**
- Other particles start to **collect on the surface** of the medium.
- Soon a **cake of solids** start to form and after a brief period the cake does the filtration.

- When the cake gets thick, it must be removed.
- Except for gas cleaning using a bag filter, cake filtration is used for **mostly liquid-solid systems**.
- As periodic removal of the cake is required which is difficult against positive pressure, most operations are **discontinuous**.
- Clarifying filter

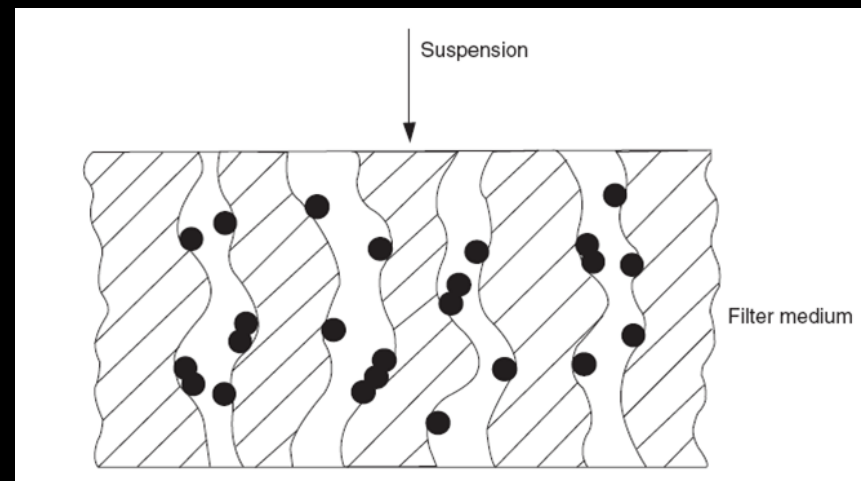

Figure 2: Schematic of clarification.

- Designed to collect a liquid that is as free from solid impurities

as possible

- The filter must be constructed in such a way as to remove the very smallest particles suspended in the liquid
- Cross-flow filter

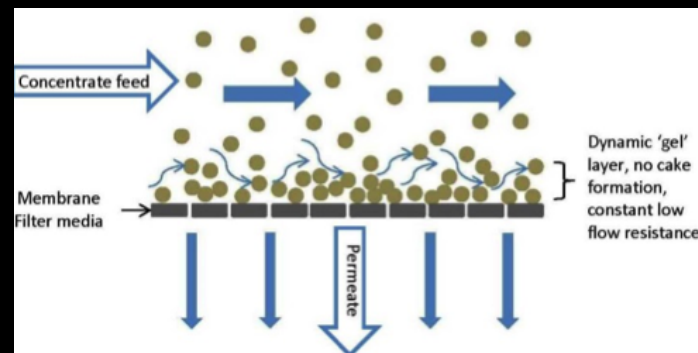

Figure 3: Schematic of cross flow filtration

- In cross flow filtration, flow occurs tangentially across the filter
- As the slurry flows across the filter it is concentrated
- The tangential flow creates a shearing effect on the filter surface that reduces particle accumulation

- Because cross flow removes build up from the filter surface, filtrate flow does not drop as fast when compared to cake filtration

1.7 Uses of filtration

- Purification
 - Produce water, chemicals, and pharmaceuticals clean, pure and free of contaminants
 - Water treatment: eliminating sediment, sand, gravel, carbon and other suspended particles
- Protect Equipment
 - Help protect expensive machinery that can be damaged by particles in the fluid
 - Pump can be damaged if abrasive materials are present in the liquid
- Safety
 - Filtration can be used to avoid cross contamination, maintain

workplace safety

- Product Isolation

- Solid and/or liquid products need to be separated from each other
- Crude oil separated from sand from the rig for further processing

2 Plate and frame filter press

2.1 Operational procedure

- Plate and frame filters consist of **plates and frames assembled alternatively** with a filter cloth over each side of the plate.
- The **plates have channels** cut in them so that clear filtrate liquid can drain down each plate.
- The feed slurry is pumped into the press and flows through the duct into **each of the open frames** so that slurry fills the frame.
- The filtrate flows through the filter cloth and the solids build up as a **cake on the frame side** of the cloth.
- The filtrate flows between the filter cloth and the face of the plate through the channels to the outlet.

- The filter press may have separate discharge to the open for each frame or all of the outlets may go to a common header.
- The filtration proceeds **until the frames are completely filled** with solids. At this point, the frames and plates are separated and the cake is removed.
- The press is then **reassembled and the cycle is repeated**.

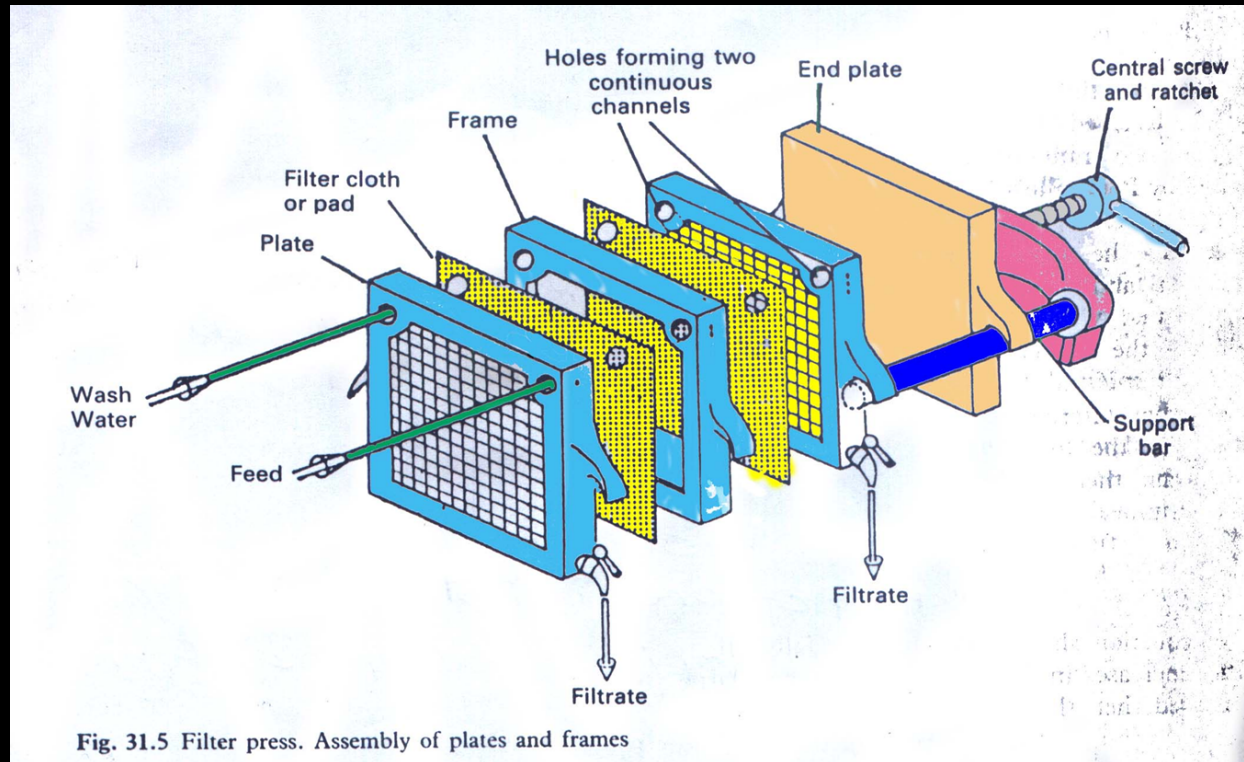

Figure 4: Plate and frame filter press.

2.2 Advantages of filter press

- Construction is very simple and a wide variety of materials can be used.
- It provides a large filtering area in a relatively small floor space.
- It is versatile, the capacity being variable according to the thickness of the frames and the number used.
- The construction permits the use of considerable pressure difference.
- Efficient washing of the cake is possible.
- Operation and maintenance is straightforward , because there no moving parts, filter cloths are easily renewable and, because all joints are external, any leaks are visible and do not contaminate the filtrate.

2.3 Disadvantages of filter press

- Are **not suitable for high-throughput processes**.
- It is a **discontinuous** filter, so it is a time consuming.
- The filter press is an **expensive** filter, the emptying time, the labour involved, and the wear and tear on the cloths resulting in high costs.
- Operation is critical, as the **frames should be full**, otherwise washing is inefficient and the cake is difficult to remove.
- In view of the **high labour costs**, it is most suitable for expensive materials, e.g. the removal of precipitated proteins from insulin liquors.

3 Rotary vacuum filter

3.1 Operational mode

- In large –scale operation, continuous operation is sometimes desirable and it may be necessary to filter slurries containing a high proportion of solids.
- The rotary filter is continuous in operation and has a system for removing the cake that is formed , so, it is suitable for use with concentrated slurries.

3.2 Structure

- It is a metal cylinder mounted horizontally, the curved surface being a perforated plate, supporting a filter cloth.
- Internally, it is divided into several sectors and a separate connection is made between each sector and a special rotary valve.

3.3 Operational procedure

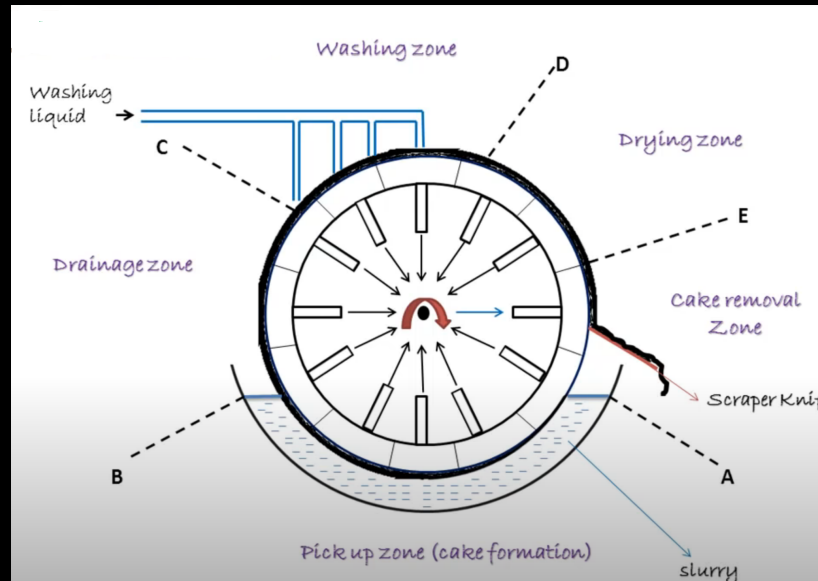

Figure 5: Schematic of a rotary vacuum filter.(Image source: Ahmed Abdel0Moneim Ali, Cairo University)

- The drum is immersed to the required depth in the slurry, which is agitated to prevent settling of the solids,
- vacuum is applied to those sectors of the drum which is submerged.

- A cake of the desired thickness is produced by adjusting the speed of rotation of the drum.
- Each sector is immersed in turn in the slurry.
- When the cake has formed, the cake drained or partially dried by vacuum.
- The drum is sprayed with water to wash the cake.
- Finally, pressure is applied under the cloth to aid the removal of the cake.
- Removal of the washed and partially dried cake is affected by means of a doctor knife.

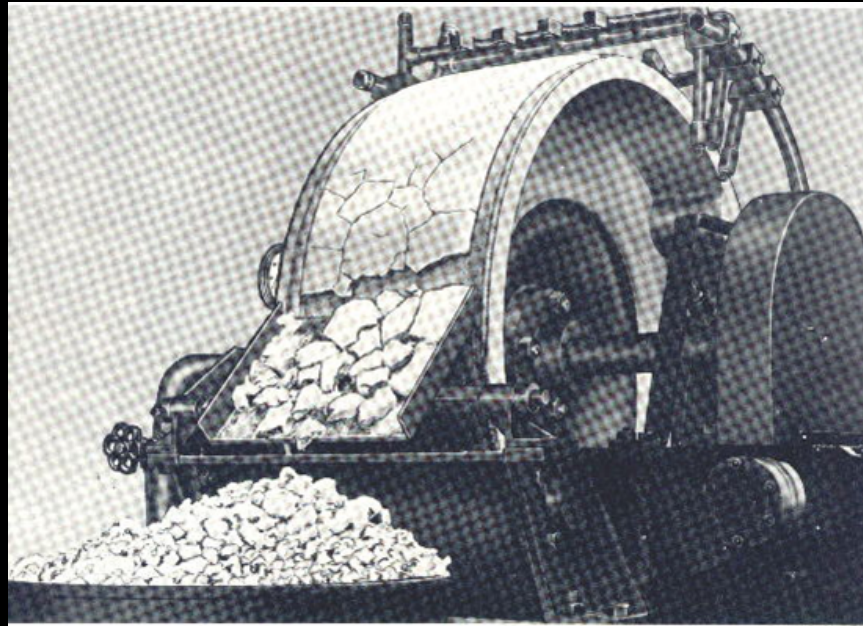

Figure 6: Cake removal from a rotary vacuum filter.

3.4 Advantages of rotary filters

- The rotary filter is automatic and is continuous in operation, so that the labour costs are very low.
- The filter has a large capacity , so it is suitable for the filtration of highly concentrated solutions.
- Variation of the speed of rotation enables the cake thickness to be controlled.
- Pre-coat of filter aid could used to accelerate the filtration rate.

3.5 Disadvantages of rotary filters

- The rotary filter is a complex piece of equipment , with many moving parts and is very expensive,.
- In addition to the filter itself, some accessories are connected ,e.g, a vacuum pump, vacuum receivers , slurry pumps and agitators are required .
- The cake tends to crack due to the air drawn through by the vacuum system, so that washing and drying are not efficient.
- Being a vacuum filter, the pressure difference is limited to 1 bar and hot filtrates may boil.
- It is suitable only for straight- forward slurries

4 **Filtration operations**

- Constant pressure filtration
- Constant flow filtration

5 Workbook: Evaluation of filter constants, filtration time and filter area for constant pressure filtration

- Problem statement:

Data for the laboratory filtration of $CaCO_3$ slurry in water at $298.2K$ ($25^\circ C$) are reported as in Table 1 at a constant pressure (Δp) of $338kN/m^2$ ($7600lb_f/ft^2$) where t is time in s and V is filtrate volume collected in m^3 . The slurry concentration was $c = 23.47kg/m^3$ ($1.465lb_m/ft^3$).

1. Calculate the specific cake resistance, α , and the filter medium resistance, R_m if the total filter area of the plate and frame filter press was $A = 0.0439m^2$ ($0.473ft^2$).
2. If the number of frames is increased to 20 with filter area of each frame $0.873m^2$ ($9.4ft^2$) and the operation is run at the same

pressure conditions, how long will it take to recover $3.37m^3$ of filtrate?

3. If you want to recover $3m^3$ of filtrate in $2min$, how many frames with area $0.873m^2$ should you use?

Table 1: Time and filtrate volume data.

$V \times 10^3$	t	t/V
0	0	
1	10.45	
2	22.14	
3	50.71	
4	66.24	

- Solution:
 - Given information:
 - V vs, t data

- Temperature $T = 25^{\circ} C$
- Pressure drop, $\Delta p = 338 \text{ kN/m}^2$
- Filter area, $A = 0.0439 \text{ m}^2$
- Slurry concentration, $c = 23.47 \text{ kg/m}^3$
- To calculate
 1. Specific cake resistance, α and filter medium resistance, R_m .
 2. Time required to collect 3.37 m^3 of filtrate with 20 frames.
 3. Number of frame required to get 3 m^3 of filtrate in 2 min .
- 1. ● Solution strategy
 - You know that α and R_m are related to t and V according to the following equation

$$\frac{t}{V} = \frac{\mu\alpha c}{2A^2\Delta p}V + \frac{\mu R_m}{A\Delta p}$$

- This is an equation of a straight line. So if we plot $\frac{t}{V}$ vs. V , we can calculate the slope and intercept of the straight line and from these values we can estimate α and R_m .
- While other values are given, we need to get the value of μ which is the viscosity of water at $25^\circ C$. From property table of water we get $\mu = 8.937 \times 10^{-4} \text{ kg/m.s}$
- Now that you know how to do it, DO IT YOURSELF
 - To proceed estimate the values $\frac{t}{V}$ and plot it against V . To do so first locate the points and then draw the best fit line through the points.
 - From the plot find the slope and intercept. To find the slope first locate any two points on the line (not any two data points). If the points are (x_1, y_1) and (x_2, y_2) , the slope,

say a , is given by

$$a = \frac{y_2 - y_1}{x_2 - x_1}$$
$$=$$

- The intercept, say b , can be obtained directly.

$$b =$$

○ Now a and b are related to α and R_m by

$$\frac{\mu\alpha c}{2A^2\Delta p} = a$$

$$\frac{\mu R_m}{A\Delta p} = b$$

The unknowns in the equations are α and R_m which can be estimated directly.

2. ● Solution strategy

- For this case we can use the same relation; however, we have a different straight line as the slope and intercept will be different (why?).
- We know that the specific cake resistance is the property of the cake which in turn depend on the particle properties and the pressure. As the pressure remains the same, for the same slurry α remains the same.
- Also assuming that the filter medium remains the same, R_m will also be the same.
- While other properties also remain the same, the filter area changes and that will change the slope and intercept.

- You can simply calculate the new slope and intercept using

$$a_2 = \frac{\mu\alpha C}{2A_2^2\Delta p}$$
$$b_2 = \frac{\mu R_m}{A_2\Delta p}$$

- As an alternate you can use the relations

$$\frac{a_2}{a_1} = \left(\frac{A_1}{A_2}\right)^2$$
$$\frac{b_2}{b_1} = \frac{A_1}{A_2}$$

where, the subscript 1 refers to problem part 1.

- Whatever way you calculate a_2 and b_2 you can the new equa-

tion

$$\frac{t}{V} = a_2V + b_2$$

- In the above equation, if V is given, only unknown remains is t which can be directly calculated.
- Proceed
 - Find a_2 and b_2 and for $V = 3.37m^3$ find t

3. • Solution strategy

- Following the same logics in 2 we know that we will have a similar equation with different slope and intercept, a_3 and b_3 , respectively.
- However, we cannot estimate those as the area is not known.
- We can express a_3 and b_3 as a function of A_3 using

$$\frac{a_3}{a_1} = \left(\frac{A_1}{A_3} \right)^2$$
$$\frac{b_3}{b_1} = \frac{A_1}{A_3}$$

- These will give

$$a_3 = \frac{c_3}{A_3^2}$$
$$b_3 = \frac{d_3}{A_3}$$

where, c_3 and d_3 are constants.

- Finally we will have

$$\frac{t}{V} = \frac{c_3}{A_3^2}V + \frac{d_3}{A_3}$$

- With t and V known, this will result in a quadratic equation in A_3 , the only unknown.
- Proceed
 - Estimate a_3 and b_3 as a function of A_3

- Express the equation as a function of A_3 for $t = 120 \text{ s}$ and $V = 3 \text{ m}^3$.

- Solve the equation to get A_3 .

- Finally calculate the number of frame required by dividing A_3 by the area of filter for one frame.

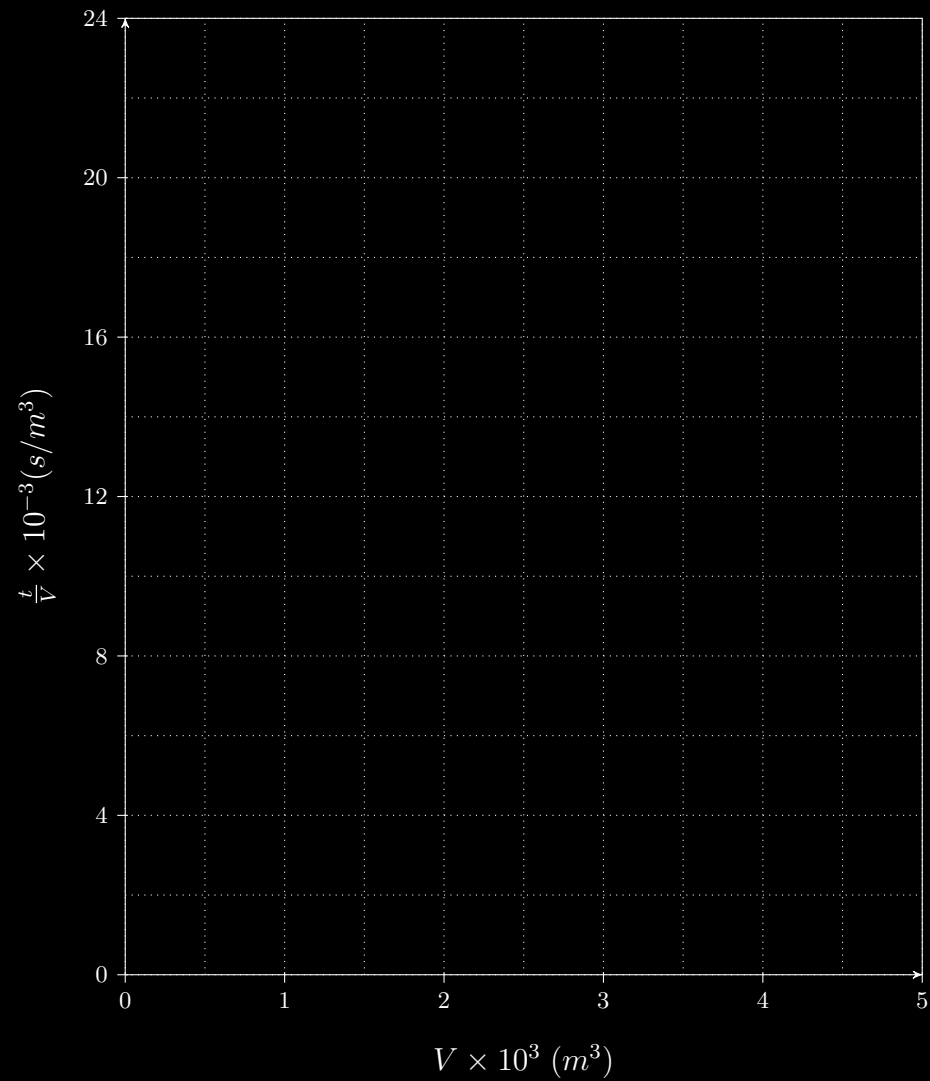

Figure 7: Plot of t/V vs. V .

6 Filtration Exercise

Figure 8 shows the t/V vs. V plot of a constant pressure filtration process. The slurry concentration was $c = 25 \text{ kg/m}^3$ and the pressure drop was recorded to be 100 kn/m^2 . The filter area was 1.25 m^2 .

1. How long should you run the process to get 10 *litre* of filtrate?
2. Find the values of specific cake resistance and filter medium resistance.
3. Redraw the plot for the case if you double the filter area.
4. Redraw the plot for the case when the solid content is twice of its current value.

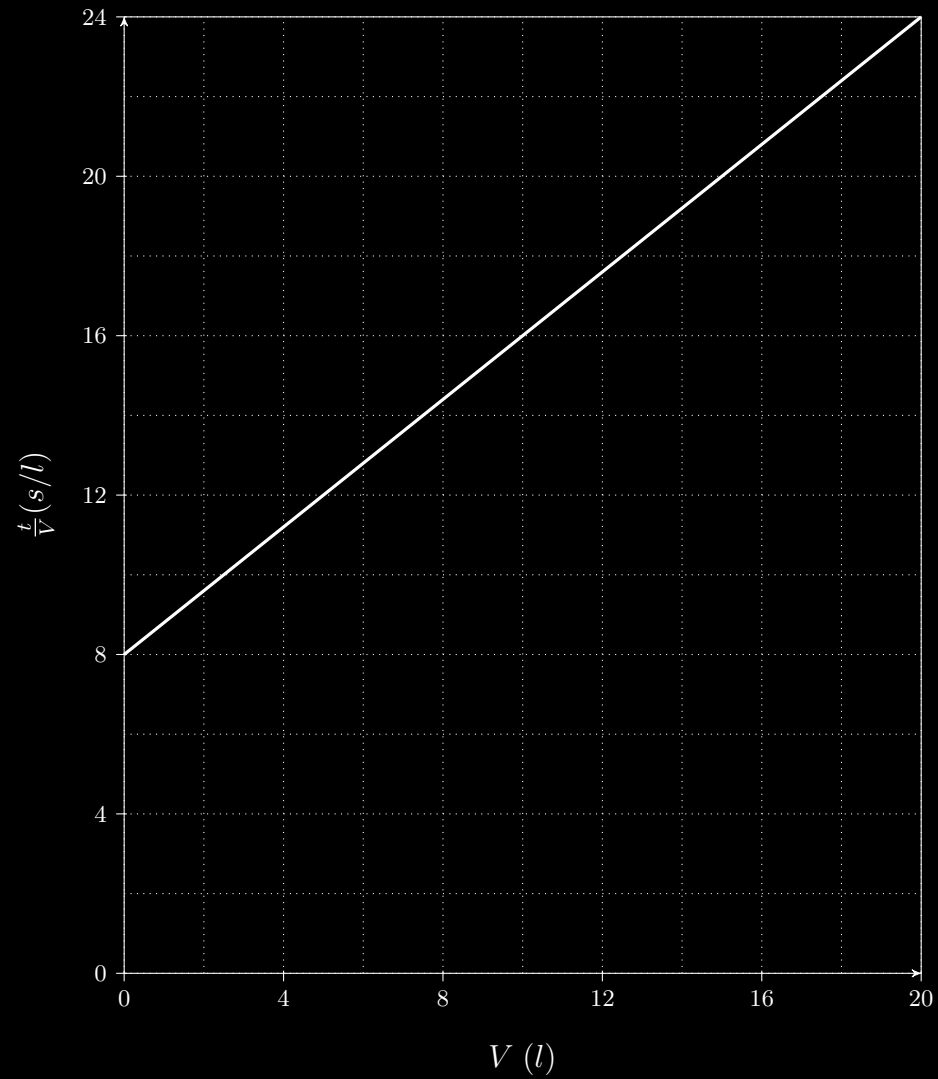

Figure 8: Plot of t/V vs. V .

References

1. W. L. McCabe, J. C. Smith, P. Harriott. (2005). Unit Operations of Chemical Engineering, 7th Edition, McGraw Hill, New York, USA. ISBN-13: 978-0-07-284823-6
2. D. Green and R.H. Perry. 2007. Perry's Chemical Engineers' Handbook, 8th Edition, McGraw-Hill. ISBN-13: 9780071422949
3. J. F. Richardson, J. H. Harker, J. R. Backhursts (2002) Coulson and Richardson's Chemical Engineering - Particle Technology and Separation Processes, Vol. 2, Fifth Ed., Butterworth-Heinemann, Oxford, UK. ISBN 0 7506 4445 1