



PROC 5071: Process Equipment Design I

Evaporators

Salim Ahmed

1 Evaporation fundamentals

1.1 Let's start with a day-to-day example

- What is Maple syrup?



Figure 1: Maple syrup comes from the Maple tree.

- Maple syrup is produced from the sap collected from Maple trees.
- The sap contains approximately 2% sugar.

- However, Maple syrup contains approximately 66% sugar.
- The increase in sugar content is obtained by decreasing the water content i.e. by removing water.



Figure 2: From sap to syrup.

1.2 Evaporation basics

- We need to **remove part of the solvent** (water) to produce a concentrated solution.
- This can be achieved by heating the solution so as to **evaporate the solvent** (water).
- This process is known as **evaporation**.
- The industrial equipment used for this purpose is known as an **evaporator**.

1.3 Evaporation: Definition

- Literally “evaporation” refers to the process by which a substance is converted **from a liquid state into**, and carried off in, **vapor**.
- In process industries, evaporation is conducted to **vaporize a portion of the volatile solvent** from a solution of **nonvolatile solute** to produce a thick liquor.
- In general, the thick liquor is the **desired product** and the vapor is discarded. Exception is the production of potable water from saline water.

1.4 An industrial example of evaporation

- In paper making, to **produce pulp** from wood chips in the digester, sodium hydroxide and sodium sulfide are used to separate lignin from the cellulose fibres.
- Lignin residues, hemicellulose, and the inorganic chemicals used in the process result in the **black liquor**.
- The black liquor comprises **15% solids** by weight.
- Approximately **7 tonnes** of black liquor are produced in the manufacture of **one tonne of pulp**.
- Black liquor is quite **toxic to aquatic life**, and causes a very dark caramel color in the water.
- The black liquor contains more than half of the **energy content** of the wood fed into the digester.

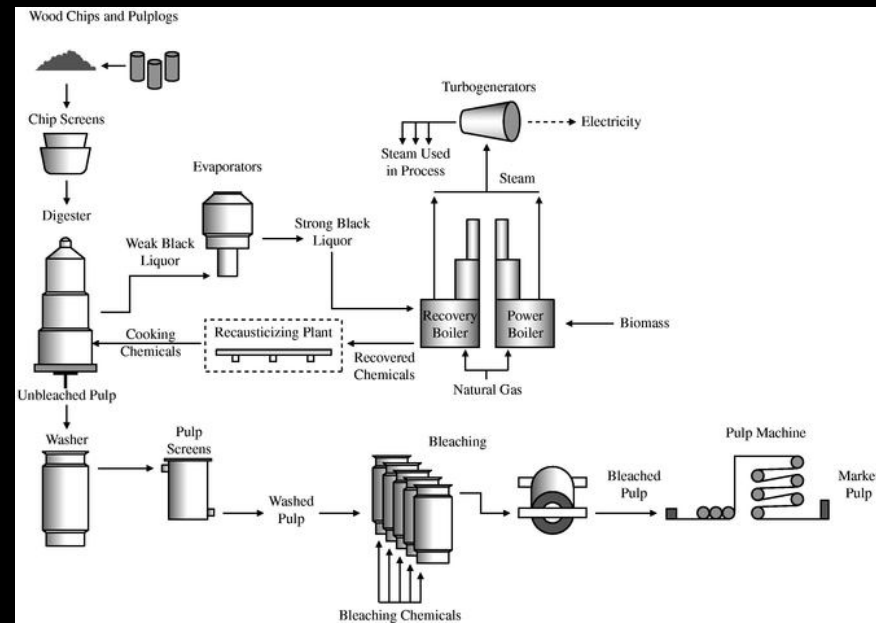

Figure 3: The pulp and paper process.

- It is normally concentrated to 65 - 80% by multi-effect evaporators and burned in a recovery boiler to produce energy and recover the cooking chemicals.

1.5 Evaporation and other unit operations

- **Drying** - the residue is solid; evaporation - the residue is liquid.
- **Crystallization** - focus of forming crystals; evaporation - emphasize on concentrating the solution.
- **Distillation** - vapor is multicomponent, main product; evaporation - vapor is often single component.

2 Industrial use of evaporation

- **Food**
 - Evaporated milk, condensed milk, cream
 - Fruit juice, pulp
 - Puree, herbal extracts, coffee, tea
- **Chemical**
 - Dyes, glycerine, paints, pigments
 - Agro chemicals
 - Caustic soda, chlorides, sulphates
 - Monomers and polymers
- **Pharmaceutical**
 - Herbicides and insecticides
 - Separation and purification

- Deodorization and decoloring
- Wastewater treatment
 - Concentration of wastewater for subsequent incineration
 - Concentration of RO membrane rejects
 - Deodorization

3 Factors affecting evaporator operation and design

- **Liquid concentration**
 - Feed is generally dilute.
 - As evaporation goes on, density and viscosity increases affecting heat transfer; viscosity of black liquor may increase by ten folds.
 - Crystals may form which must be removed to avoid tube clog; High level of tartrates in Concord grape can crystallize.
 - Boiling point may rise considerably; Above 95%, ammonium nitrate has an extremely high boiling point elevation.
- **Foaming**
 - Foam may accompany the vapor causing heavy entrainment.
 - Organic substances has more foaming tendency
 - Caustic solutions, skim milk and some fatty acids form foam or

froth.

- **Temperature sensitivity**

- Pharmaceutical and food products as well as fine chemicals may get damaged when heated at moderate to high temperature.
- Examples include milk, juice, vegetable extracts, medicine.
- Exposure to low heat source for long time may also affect quality.
- Specials techniques are needed to reduce both the temperature and the time of heating.

- **Scaling**

- Scales affects the heat transfer considerably.
- Higher solid content may accelerate scaling.
- Cleaning of evaporators is to be done.
- In phosphoric acid production by the digestion of phosphate rock in sulfuric acid, calcium sulfate is a constituent which causes

scaling.

- **Materials of construction**

- Commonly steel; many duties can be handled with 316 stainless steel.
- For solutions attacking ferrous materials copper, nickel, stainless steel are also used.
- For some applications where chloride ions are present, higher grades of stainless steel, such as 904L, can be an economic selection.
- Certain products are so corrosive that they cannot be processed in conventional metals. As an example, concentration of a sulfuric acid solution of up to 50% at 150°C would call for main plant items of filament wound fiberglass reinforced epoxy resin, and heating and cooling surfaces of impervious graphite.

- **Other liquid properties:** specific heat, heat of concentration, freezing point, toxicity etc.

4 Types of evaporators

Heat is provided in an evaporator by the condensation of a vapor such as steam on one side of a metal surface with the evaporating liquid on the other side. The classification of equipment depends primarily on

- the configuration of the heat transfer surface
- means employed to provide circulation or agitation

Depending on these two criteria, there are different types of evaporators.

4.1 Open kettle or pan

- Liquid boiled in an open kettle

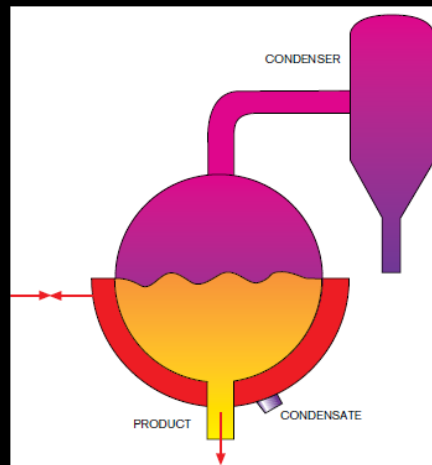

Figure 4: Open kettle evaporator.

- Heat supplied by condensation of steam in a jacket or coils or by direct firing.
- Inexpensive, simple, but heat economy is poor.

4.2 Horizontal tube natural circulation evaporator

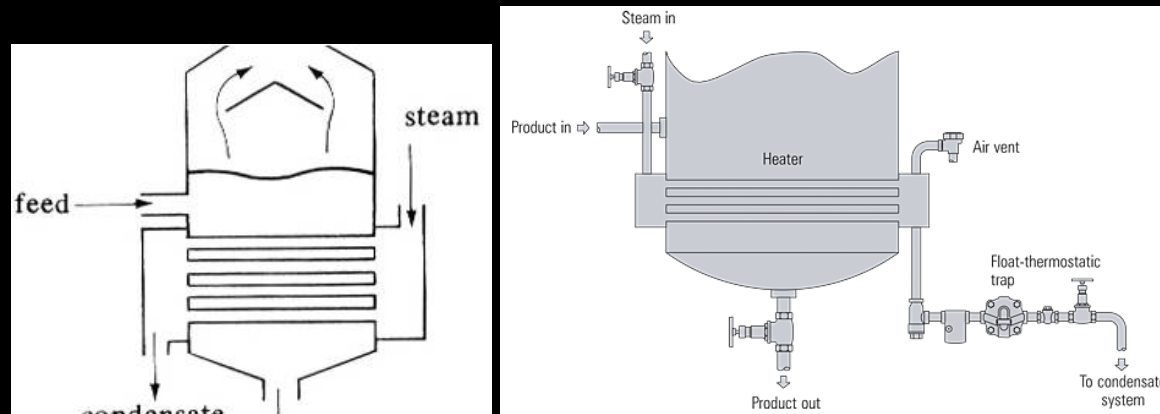

Figure 5: Horizontal tube evaporator.

- Steam enters in a bundle of horizontal tubes and condenses; condensate leaves at the other end.
- Boiling liquid covers the tubes; the vapor leaves from the liquid surface.
- Cheap and used for nonviscous liquids with high heat transfer coefficient and less scaling tendency.

4.3 Vertical tube natural circulation evaporator

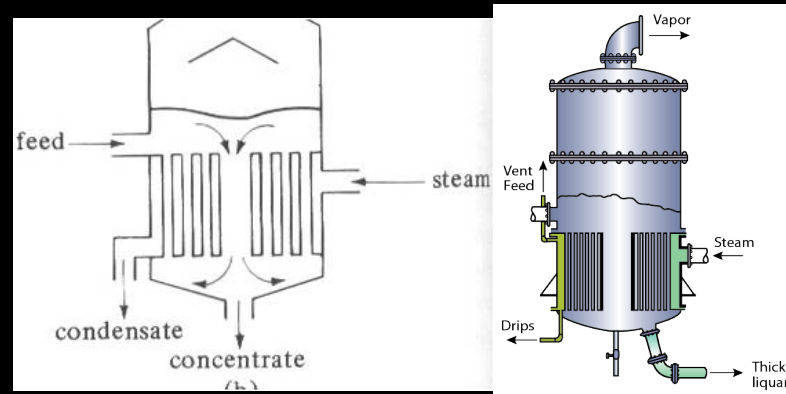

Figure 6: Vertical tube natural circulation evaporator.

- Liquid inside the bundle of vertical tube, steam condenses outside.
- Boiling and decreased density causes liquid to rise in the tubes by natural circulation.
- Liquid flows downward through a large, central open space or a downcomer.
- Not suitable for viscous liquids.

4.4 Long tube vertical evaporator

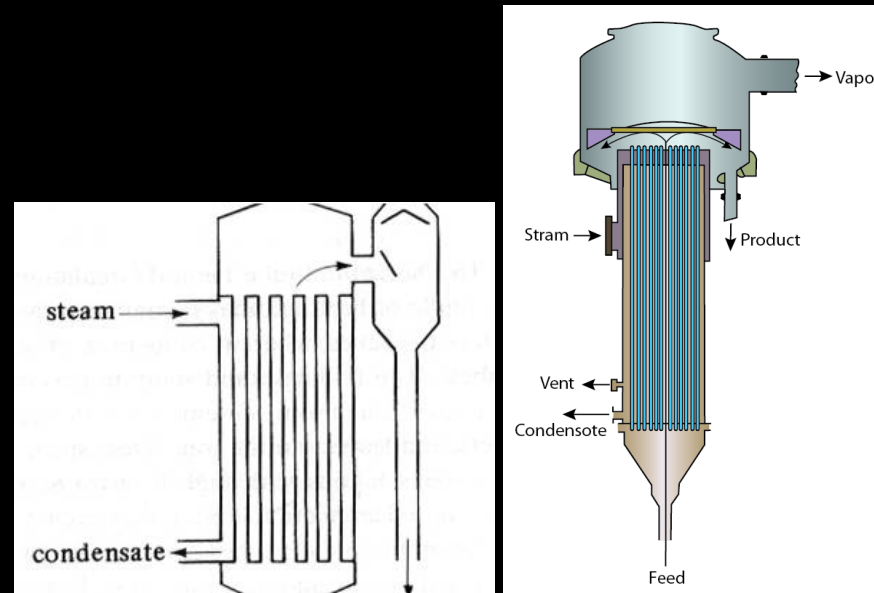

Figure 7: Long tube vertical evaporator.

- Liquid goes through long vertical tubes.
- Formation of vapor bubbles inside tubes causes a pumping action giving high liquid velocities.

- High liquid velocities are desired as the steam side heat transfer coefficient is high.
- High velocity gives lower contact time.

4.5 Falling film evaporator

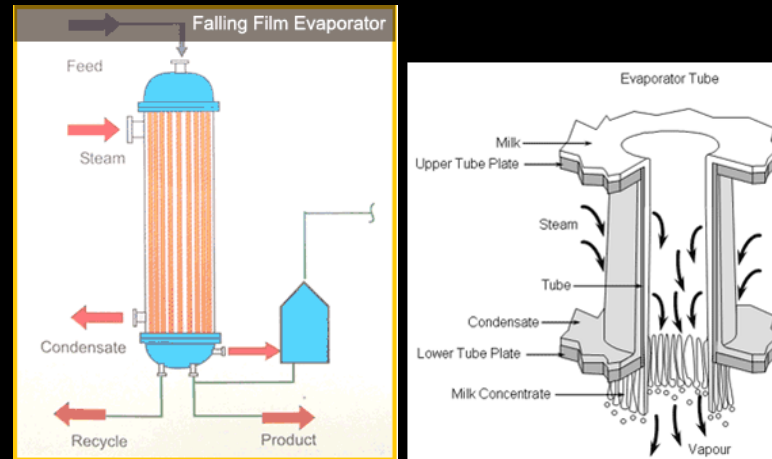

Figure 8: Falling film evaporator.

- A variation of the LTVE where the liquid is fed at the top and flows down the walls of the tubes as a thin film.
- Vapor liquid separation usually takes place at the bottom.
- Widely used for concentrating heat sensitive materials as the hold up time is low and heat transfer coefficient is high.

4.6 Forced circulation evaporator

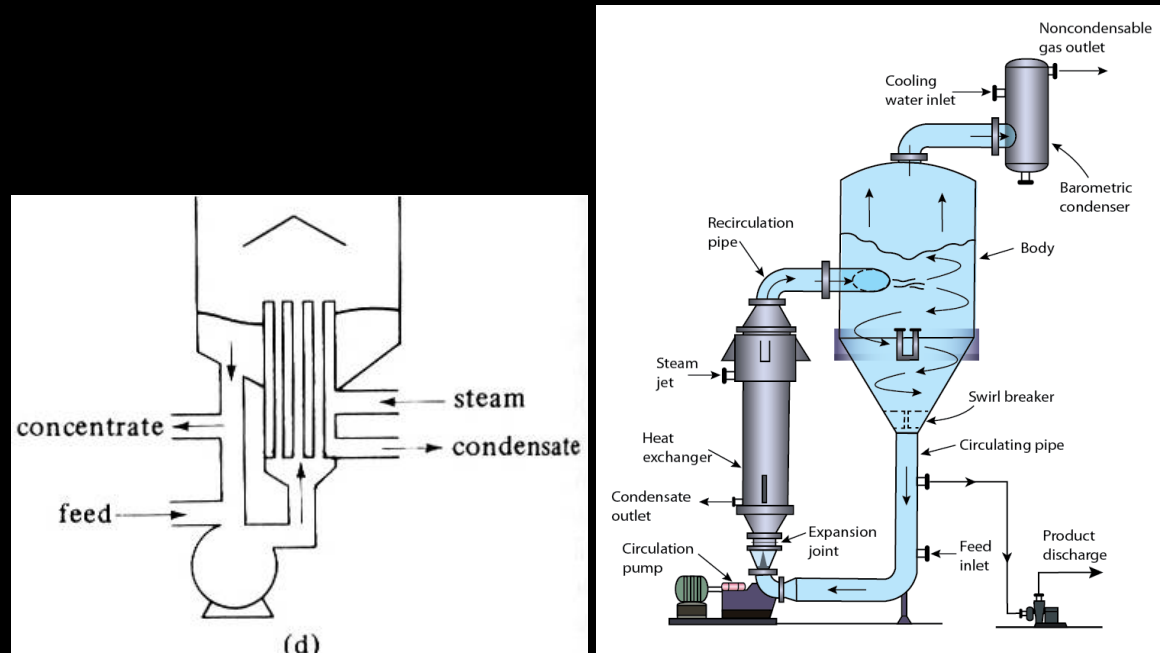

Figure 9: Forced circulation vertical tube evaporator.

- The liquid side heat transfer coefficient can be increased by pumping to cause forced circulation of the liquid.
- Very useful for viscous liquids.

4.7 Agitated film evaporator

- The main resistance to heat transfer in an evaporator is on the liquid side.
- One way to increase the heat transfer coefficient for the liquid side is to increase turbulence by mechanical agitation.
- Agitated film evaporator is modified falling film evaporator with a single large jacketed tube containing an internal agitator.
- Liquid enters at the top and as flows downward, it is spread out into turbulent film by the vertical agitator blade.
- Suitable for highly viscous heat sensitive materials.
- Small capacity, high cost.

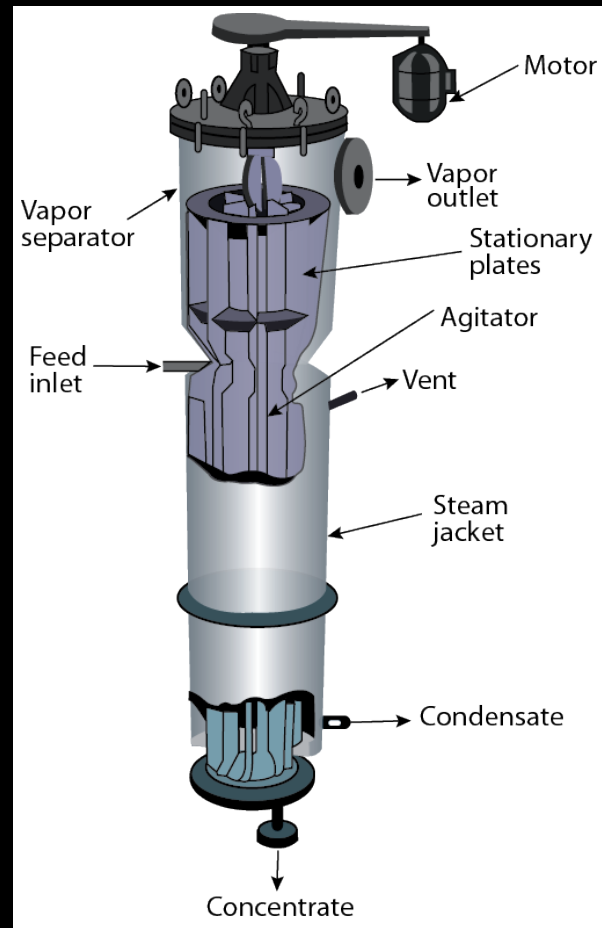

Figure 10: Agitated film evaporator.

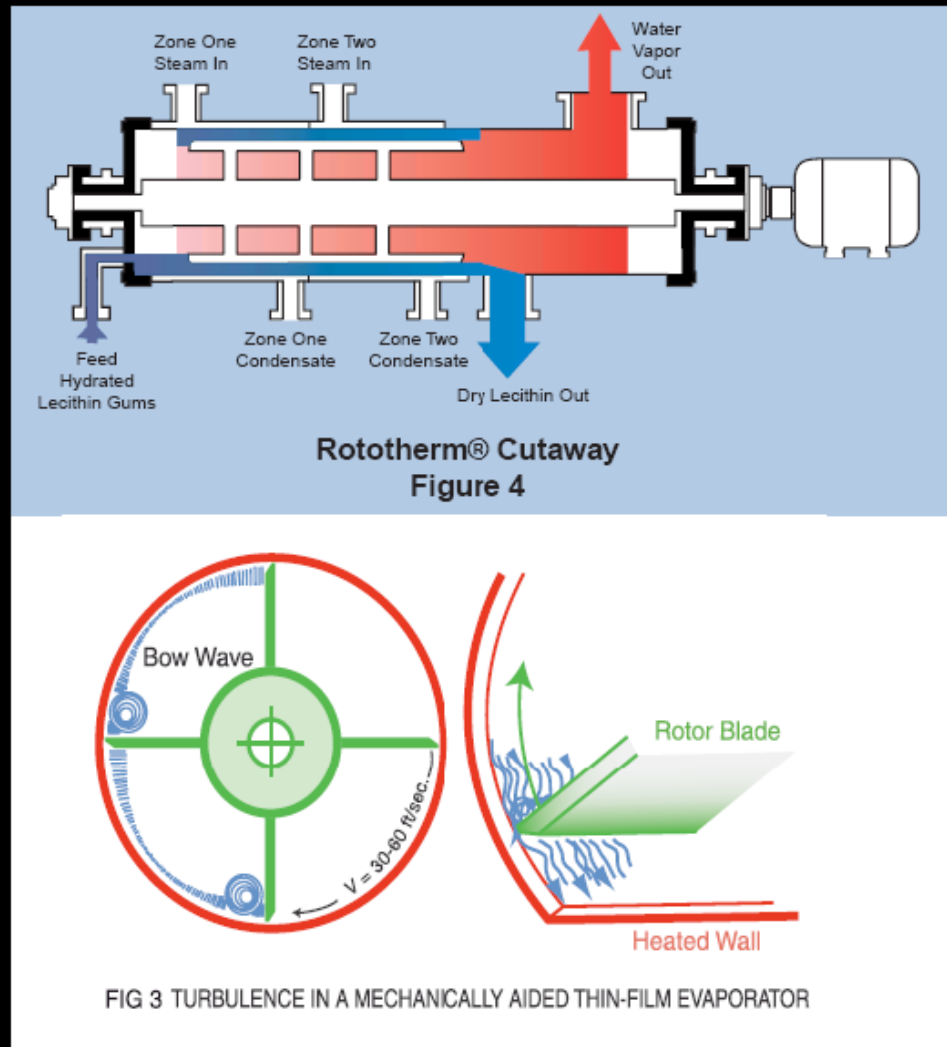

Figure 11: Thin film evaporator.

4.8 Open-pan solar evaporator

- Liquid in open pan allowed to evaporate in the sun.



Figure 12: Open pan evaporation for production of salt.

- Used mainly for salt production.

5 Methods of operation

5.1 Single effect evaporators

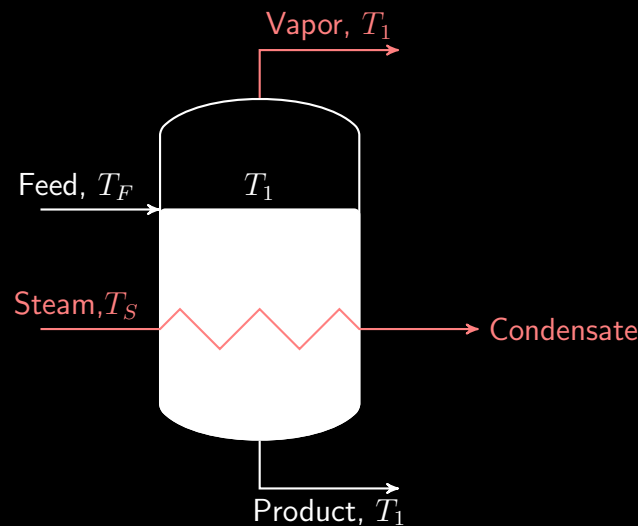

Figure 13: Schematic of a single effect evaporator.

- Saturated steam enters at T_S and condenses. Latent heat is transferred.

- The liquid solution is at its boiling point T_1 .
- Assuming complete mixing, the concentrated solution is also at T_1 .
- The vapor being in equilibrium with the liquid, its temperature is also T_1 .
- If the solution is dilute like water and T_F is near the boiling point T_1 , $1kg$ of steam will produce approximately $1kg$ of vapor.
- The general heat transfer equation can be written as

$$q = UA\Delta T = UA(T_s - T_1)$$

- Single step evaporators are used when the capacity is small and/or the cost of steam is cheap compared to the cost of product.

5.2 Forward feed multiple effect evaporators

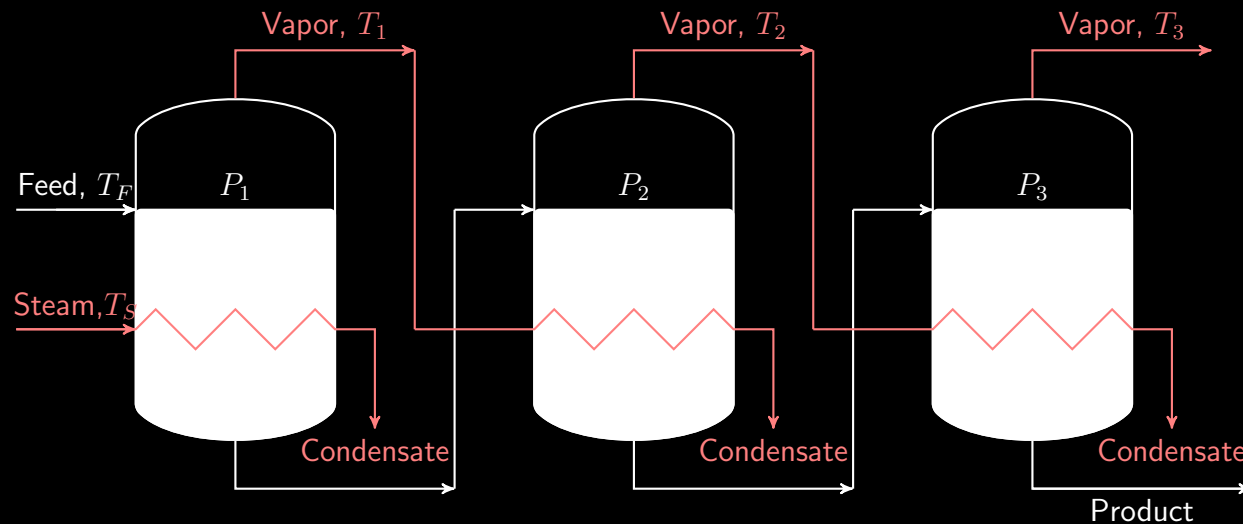

Figure 14: Schematic of forward feed three effect evaporator.

- The latent heat of the vapor produced in a single effect evaporator is discarded.
- In multiple effect evaporators, this latent heat is recovered.
- Vapor produced in the first evaporator is used as the heating

medium for the second effect while the concentrated solution from the first step is the feed for the second.

- Heat transfer is attained by operating the second evaporator at a lower pressure than the first one.
- The same mechanism follows for the second and third unit and so on.
- Roughly, almost $3kg$ vapor can be produced if there are three units. Note that only $1kg$ of steam is used.
- However, additional units require additional fixed cost.
- In forward feed operation, the fresh feed is added to the first unit and flows to the next in the same direction as vapor.
- This configuration is suitable when the final product may be damaged at high temperature.

5.3 Backward feed multiple effect evaporators

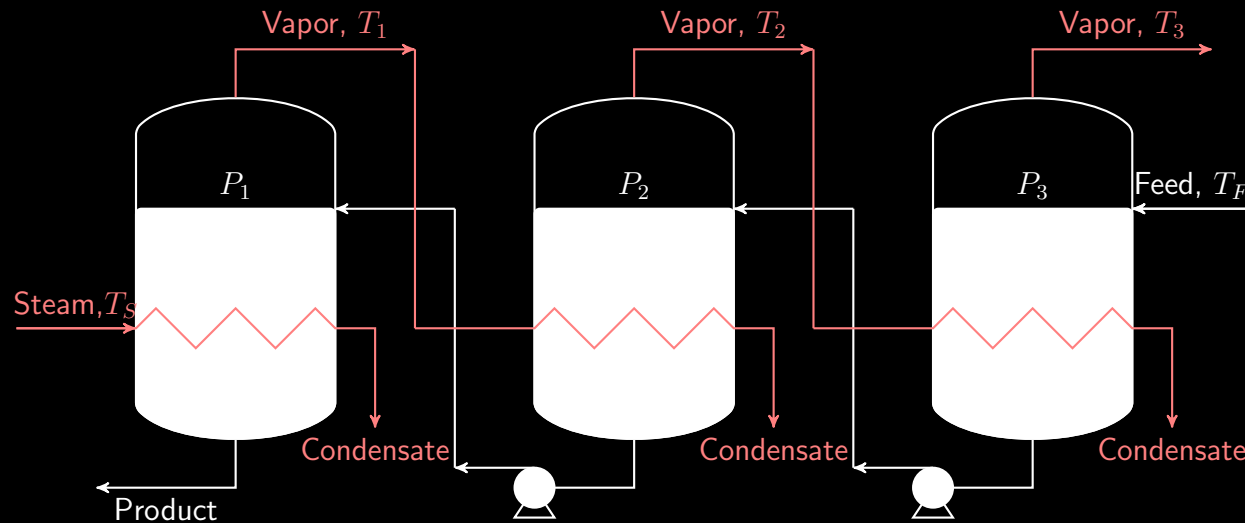

Figure 15: Schematic of backward feed three effect evaporator.

- In backward feed operation, the feed enters at the last and coldest effect and the concentrated product leaves the first effect.
- This is advantageous when the fresh feed is cold, since it will require a small temperature rise.

- Liquid pumps are required for each effect as the liquid flows from lower to higher pressure.
- Backward flow is advantageous when the concentrated liquid is viscous. The high temperatures at the early effects reduces liquid viscosity giving reasonable heat transfer coefficient.

5.4 Parallel feed multiple effect evaporators

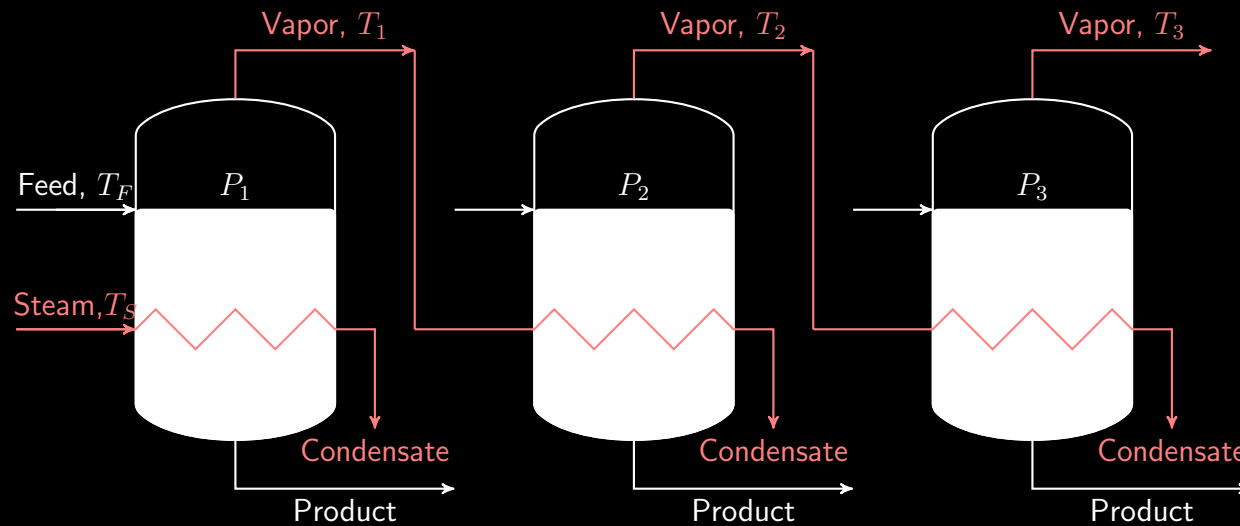

Figure 16: Schematic of backward feed three effect evaporator.

- In parallel feed, fresh feed is introduced at and concentrated solution is withdrawn from each effect.
- Suitable when the feed is almost saturated and the solid crystals are the product as in the case of evaporating brine to produce salt.

6 Performance of tubular evaporators

The performance of tubular evaporators are measured using two criteria:

1. **Capacity**: defined as the number of kilograms vaporized per hour.
2. **Economy**: defined as the number of kilograms vaporized per kilogram of steam used.

Both capacity and economy are related to the rate of heat transfer given by

$$q = UA\Delta T$$

The feed temperature also affects the capacity and economy.

- If the feed is at its boiling point, almost all of q is available for evaporation and the capacity is nearly proportional to q .

- As evaporation proceeds, the boiling point rises and some sensible heat is required. However, the sensible heat is small compared to the heat of evaporation.
- If the feed is cold, sensible heat may be large and capacity for a given q may be significantly reduced.
- If the feed is above its boiling point corresponding to the vapor space, part of the feed evaporates spontaneously and capacity is higher than that corresponding to q .
- The actual temperature drop across the heating surface depends on the solution being evaporated, the difference in pressure between the steam chest and the vapor space above the liquid and the depth of liquid over the heating surface.
- In actual evaporators, the boiling point is affected by two factors: boiling point elevation and liquid head.

6.1 Boiling point elevation

- The vapor pressure of aqueous solutions is less than that of water at same temperature.
- Consequently, for a given pressure the boiling point of the solution is higher than that of pure water.
- The increase in boiling point over that of water is known as the boiling point elevation (BPE) of the solution.
- BPE increases with the concentration of the solute in the solution. It may be as high as $80^{\circ}C$.
- BPE is best found from an empirical rule know as *Dühring's rule*. |

6.2 *Dühring's rule*

- This rule states that the boiling point of a solution is a linear function of the boiling point of water.
- If the BP of a solution is plotted against that of water, it will result in a straight line.

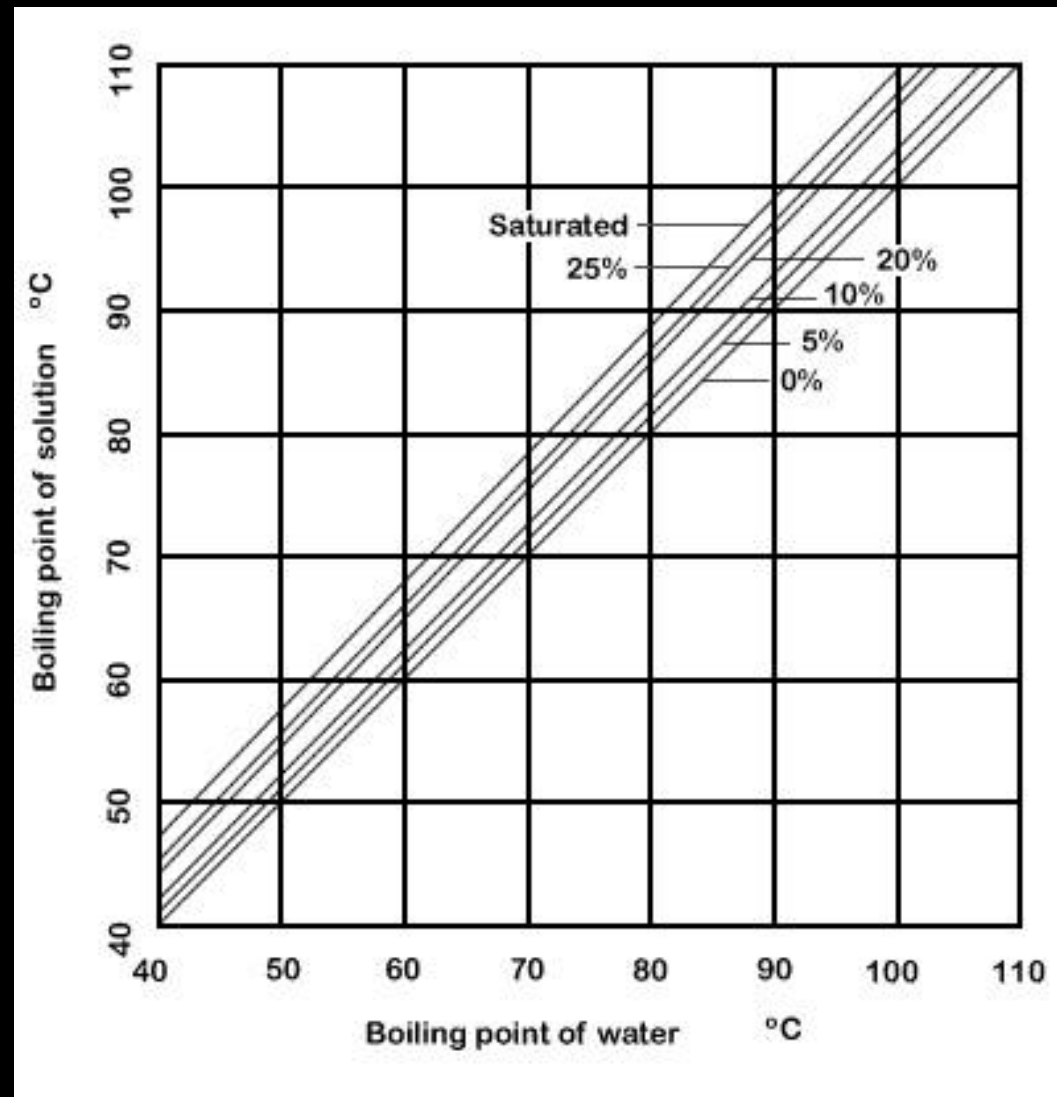
Figure 17: An example of *Dühring's* plot.

7 Design Calculations

7.1 Typical design requirements

- Design calculations for evaporators typically involves the determination of
 1. The heat transfer area required.
 2. The amount of steam required.
 3. The steam economy.
- Design may involve single or multiple effect evaporators.

7.2 Design equations

- Design equations for any equipment include one or more of the balance equations namely
 1. The material balance
 2. The energy balance
 3. The momentum balance
- Along with the balance equations, governing equations for one or more of the followings are involved.
 1. Mass transfer
 2. Heat transfer
 3. Thermodynamic relations
- For evaporators, momentum balance is not important.
- Mass transfer is simplified as only the solvent evaporates.

- Thermodynamic considerations include
 - Boiling point elevation
 - Effect of feed temperature, evaporator pressure and steam pressure.

7.3 Materials balance

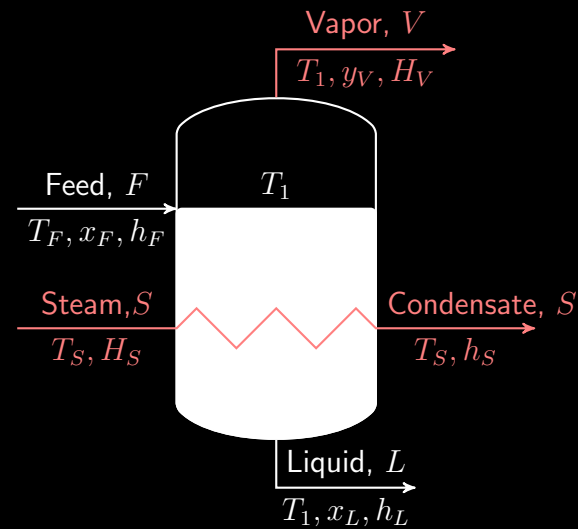

Figure 18: Schematic of a single effect evaporator.

- At a steady state

$$\left\{ \begin{array}{l} \text{Rate of} \\ \text{mass in} \end{array} \right\} = \left\{ \begin{array}{l} \text{Rate of} \\ \text{mass out} \end{array} \right\}$$

- For the overall balance

$$F = L + V$$

- The solute balance

$$F x_F = L x_L$$

7.4 Energy balance

- With an assumption of no heat loss

$$\left\{ \begin{array}{l} \textit{Rate of} \\ \textit{energy in} \end{array} \right\} = \left\{ \begin{array}{l} \textit{Rate of} \\ \textit{energy out} \end{array} \right\}$$

- Energy involved in evaporation is the heat energy.
- The inlet streams are the feed and the steam.

$$\left\{ \begin{array}{l} \textit{Rate of} \\ \textit{energy in} \end{array} \right\} = \left\{ \begin{array}{l} \textit{Rate of} \\ \textit{energy} \\ \textit{in feed} \end{array} \right\} + \left\{ \begin{array}{l} \textit{Rate of} \\ \textit{energy} \\ \textit{in steam} \end{array} \right\}$$
$$= Fh_F + SH_S$$

- The outlet streams are the liquid, the vapor and the condensate.

$$\begin{aligned}
 \left\{ \begin{array}{l} \text{Rate of} \\ \text{energy out} \end{array} \right\} &= \left\{ \begin{array}{l} \text{Rate of} \\ \text{energy out} \\ \text{with liquid} \end{array} \right\} \\
 &+ \left\{ \begin{array}{l} \text{Rate of} \\ \text{energy out} \\ \text{with vapor} \end{array} \right\} \\
 &+ \left\{ \begin{array}{l} \text{Rate of} \\ \text{energy out} \\ \text{with condensate} \end{array} \right\} \\
 &= Lh_L + VH_V + Sh_S
 \end{aligned}$$

- The energy balance gives

$$Fh_F + SH_S = Lh_L + VH_V + Sh_S$$

- Amount of heat transferred from the steam is given by

$$q = SH_S - Sh_S = S\lambda$$

- So we get

$$q = Lh_L + VH_V - Fh_F$$

7.5 Governing equation for heat transfer

The basic equation for heat transfer is always applicable.

$$q = U A \Delta T$$

8 Workbook: Determination of heat transfer area for a single effect evaporator

The problem

You have been assigned to design an evaporator to concentrate $10,000\text{kg/h}$ of a $1.0\text{wt}\%$ salt solution at 25°C to a final concentration of $2.0\text{wt}\%$. The vapor space of the evaporator should be at 1atm and saturated steam is available at 1.67atm . For the specified type of evaporator, the overall heat transfer coefficient would be $1750\text{W}/\text{m}^2\cdot\text{K}$.

1. What should be the heat transfer area of the evaporator?
2. Determine the steam economy for the evaporator.
3. Find the steam economy if the feed was saturated liquid at 1atm ?

Solution

Problem analysis:

- From the governing equation for heat transfer

$$q = U A \Delta T$$

- The required area can be obtained as

$$A = \frac{q}{U \Delta T}$$

- With U given, to get A we need q and ΔT .
- From the given pressures, ΔT can be obtained.

$$\Delta T = T_S - T_1$$

- T_S is the temperature of steam, T_1 is the boiling point of the

liquid.

- To get q

$$q = S\lambda$$

- where, λ can be obtained from steam table, S can be obtained from the heat balance

$$S\lambda = Lh_L + VH_V - Fh_F$$

- Here, L and V can be obtained from material balance.
- The enthalpy values can be calculated by choosing a suitable reference.

Solution:

- Let's first determine V and L . Note that L can be directly ob-

tained from the solute balance.

$$F x_F = L x_L$$

- Giving

$$L = \frac{F x_F}{x_L}$$

=

=

- From the overall balance

$$V = F - L$$

=

=

- To get h_L , H_V and h_F , we need to choose a reference temperature.
- It is convenient to choose T_1 which is the evaporator temperature as the reference.
- The pressure in the evaporator is 1atm . Assuming the solution properties as that of water

$$T_1 =$$

- With T_1 as the reference

$$h_L =$$

- H_V is the latent heat of vaporization at 100°C .

$$H_V =$$

- Now

$$h_F = c_{pF}(T_F - T_{ref})$$

- For the feed, we can assume the specific heat as that of water

$$c_{pF} = 4.15 \text{ kJ/Kg.K}$$

- With $T_{ref} = T_1$

$$h_F =$$
$$=$$

- So we get

$$\begin{aligned}q &= Lh_L + VH_V - Fh_F \\ &= \\ &= \end{aligned}$$

- To get ΔT we need T_S which is the saturation temperature of water at 1.67atm

$$T_S =$$

- Giving

$$\Delta T = T_S - T_1 =$$

- Finally the heat transfer area is

$$\begin{aligned} A &= \frac{q}{U\Delta T} \\ &= \\ &= 152m^2 \end{aligned}$$

- To get the steam economy we need S

$$\begin{aligned} S &= \frac{q}{\lambda} \\ &= \\ &= \end{aligned}$$

- So the steam economy is

$$\begin{aligned} \text{Steam economy} &= \frac{V}{S} \\ &= \\ &= 77\% \end{aligned}$$

- if the feed was saturated liquid at $1atm$, then

$$h_F = 0$$

$$\begin{aligned} q &= Lh_L + VH_V - Fh_F \\ &= \\ &= \end{aligned}$$

- Steam requirement S would be

$$S = \frac{q}{\lambda}$$

$$=$$
$$=$$

- So the steam economy would be

$$\text{Steam economy} = \frac{V}{S}$$

$$=$$

$$= 98.2\%$$

- Also the heat transfer area would be

$$\begin{aligned} A &= \frac{q}{U\Delta T} \\ &= \\ &= 119.3m^2 \end{aligned}$$

9 Workbook: Use of the *Dühring's rule* and enthalpy concentration diagram

The Problem

An evaporator is used to concentrate a 20% aqueous solution of $NaOH$ to produce a 50% solution. If the vapor space in the evaporator is at a pressure of 1 atm , find T_1 , h_L and H_v . Also find h_F if $T_F = 40^\circ\text{C}$.

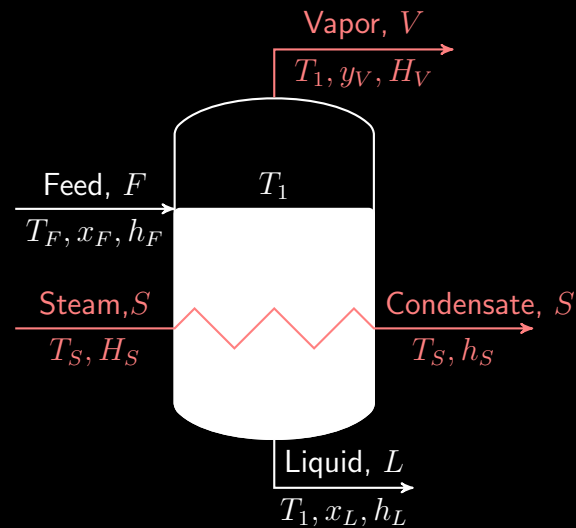

Figure 19: Schematic of a single effect evaporator.

Solution

Given:

- System: NaOH - Water
- $x_F =$
- $x_L =$

- $P_1 =$
- $T_F =$

Need to calculate:

- T_1
- h_L
- H_v
- h_F

Problem analysis:

- The concentration of the feed and the product are significantly high; so we need to consider boiling point elevation (BPE).
- T_1 is the BP of 50% NaOH solution. To find T_1 , one needs to use the *Dühring's* plot (20).

- h_L is the enthalpy of 50% NaOH solution at T_1 which can be obtained from the enthalpy concentration diagram (21).
- H_v is the enthalpy of water vapor at T_1 . Determination of H_v needs careful consideration. Due to BPE, T_1 will be higher than BP of water at $1atm$ and the vapor will be produced at T_1 . That means it will not be saturated; rather superheated.
- h_F is the enthalpy of 20% NaOH solution at $T_F = 40^\circ C$ which can be obtained from (21).

Calculations:

Calculate T_1 :

Step 1: $P_1 = 1atm$. The BP of water at P_1 is $^\circ C = \quad ^\circ F$
(Appendix 7).

Step 2: Using the *Dühring's* plot (Fig. 20), for BP of water

$100^{\circ}C$ and NaOH concentration 50%, T_1 can be obtained as

$$T_1 = \quad ^{\circ}C = \quad ^{\circ}F$$

Calculate h_L :

We need to calculate h_L using Fig.(21). Note the reference state which is "enthalpy of liquid water at $32^{\circ}F$ and vapor pressure is zero". Remember that you will have to use this reference for all enthalpy calculations. So you cannot set the reference arbitrarily.

Now to calculate h_L

Step 1 : Locate $x_1 =$ on the horizontal axis on.

Step 2 : Draw a vertical line through x_1 to reach the curve for $T_1 =$ $^{\circ}F$.

Step 3 : Draw a horizontal line through the intersection of the

vertical line through and curve for T_1 . Read h_L from the y axis

$$h_L = \text{Btu/lb} \times \frac{2.326 \text{kJ/Kg}}{1 \text{Btu/lb}} = \text{kJ/kg}$$

Calculate H_v :

V is saturated vapor at $T_1 = 143^\circ\text{C} = 289.4^\circ\text{F}$. We can calculate H_v using steam table. Remember the reference state enthalpy of saturated water at 32°F to be zero. Using the steam table (Appendix 7), at $1 \text{atm} = 14.7 \text{psi}$, the enthalpy of saturated vapor is Btu/lb and the saturation temperature is $100^\circ\text{C} = 212^\circ\text{F}$.

To obtain the enthalpy of the superheated vapor

$$\begin{aligned}
 H_v(sup) &= H_v(sat) + C_p \Delta T \\
 &= \text{Btu/lb} \\
 &\quad + (0.45 \text{ Btu/lb} \cdot ^\circ\text{F}) (\quad - \quad) ^\circ\text{F} \\
 &= \text{Btu/lb}
 \end{aligned}$$

Calculate h_F :

h_F is the enthalpy of 20% NaOH solution at $40^\circ\text{C} = \quad ^\circ\text{F}$. Following the same procedure as that for h_L we get

$$h_F = \text{Btu/lb} \times \frac{2.326 \text{ kJ/Kg}}{1 \text{ Btu/lb}} = \text{kJ/kg}$$

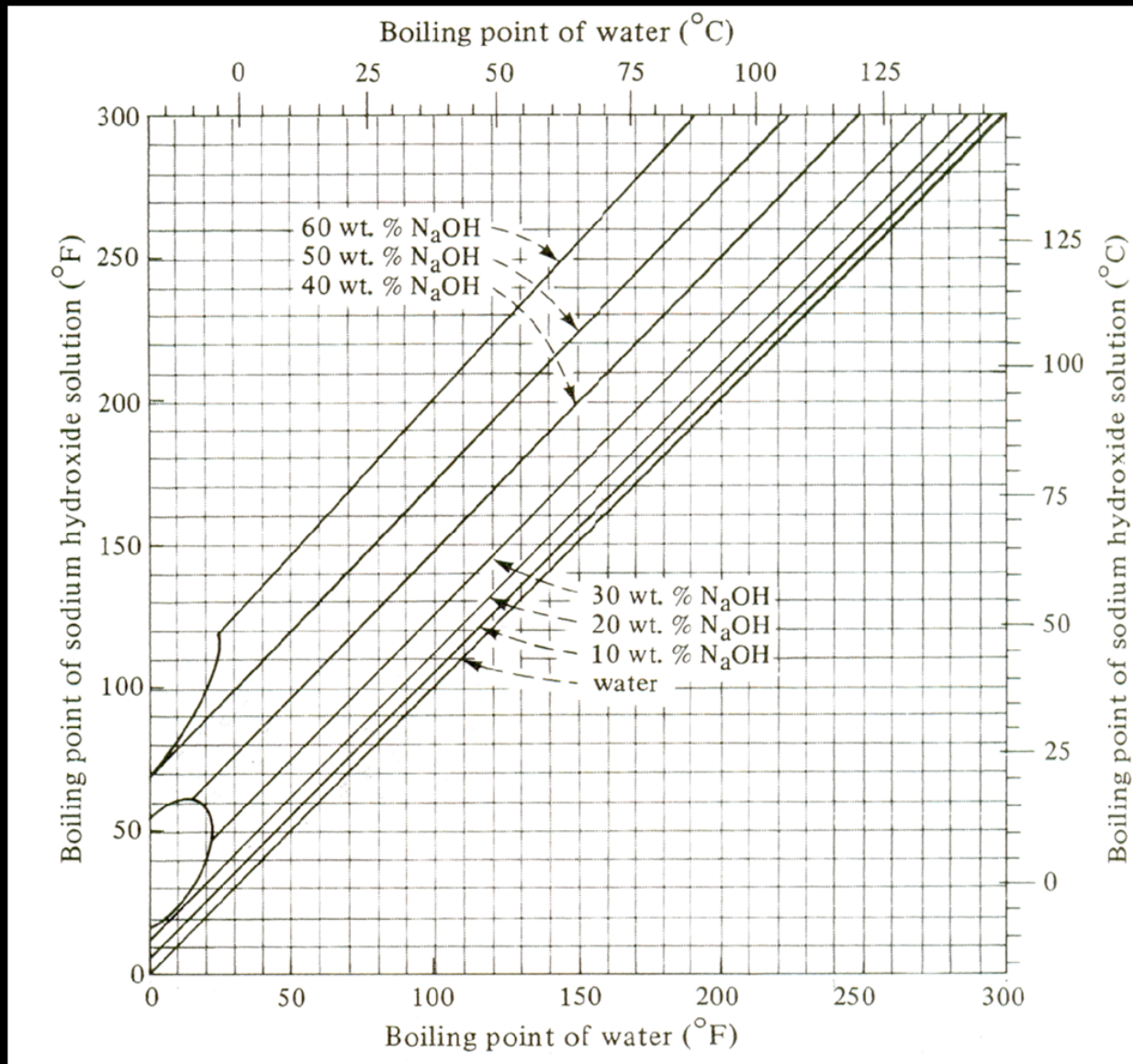

Figure 20: *Dühring's* plot for aqueous $NaOH$ solution.

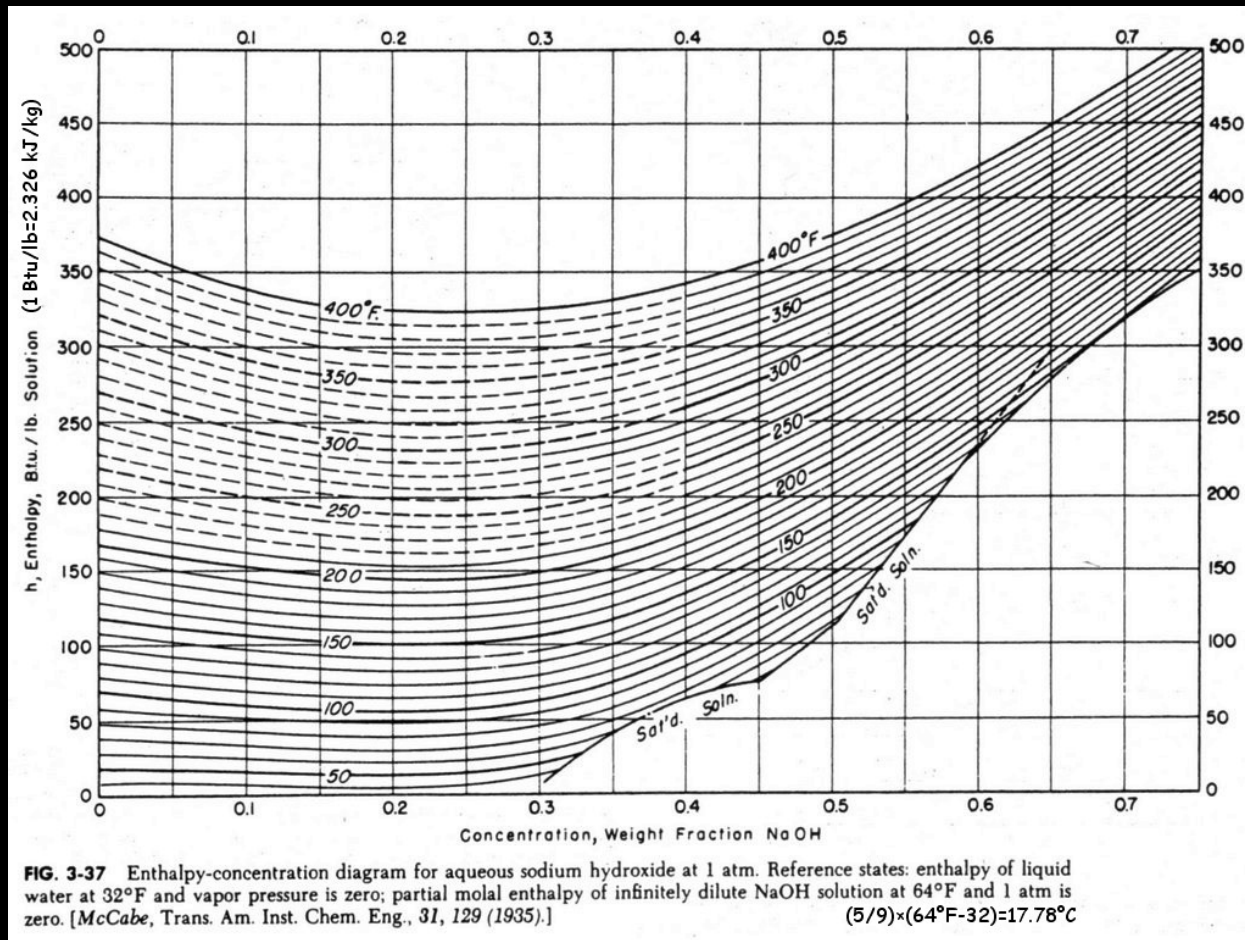

Figure 21: Enthalpy concentration diagram for aqueous $NaOH$ solution.

10 Workbook: Use of the *Dühring's rule* and enthalpy concentration diagram

The Problem

An evaporator is used to concentrate a 44% aqueous solution of $NaOH$ to produce a 65% solution using steam at 3 atm pressure. The feed temperature and the condensing temperature are both at $40^{\circ}C$. Find h_L , h_F and H_v .

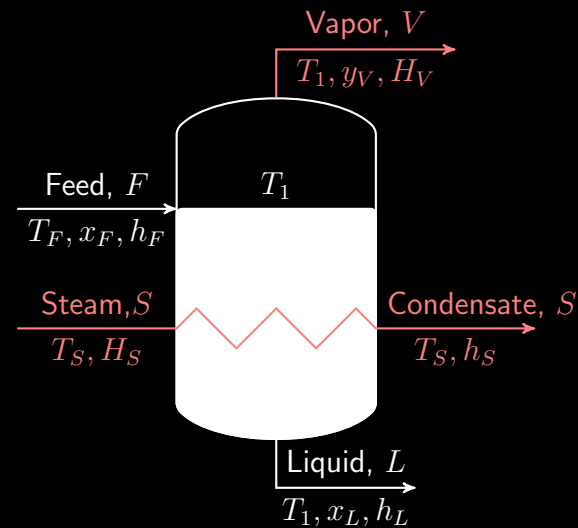

Figure 22: Schematic of a single effect evaporator.

Solution

Given:

- System: NaOH - Water
- $x_F =$
- $x_L =$

- $P_S =$
- $T_F =$
- Condensation temperature of V is

Need to calculate:

- h_L
- H_v
- h_F

Problem analysis:

- The concentration of the feed and the product are significantly high; so we need to consider boiling point elevation (BPE).
- Here P_1 is not given. So we cannot obtain T_1 directly.
- The condensation temperature of V is given . This means

that under the given pressure the BP of water is 40°C . With this BP value of water and concentration of NaOH, we can get BPE and T_1 .

- h_L is the enthalpy of 65% NaOH solution at T_1 which can be obtained from the enthalpy concentration diagram (21).
- H_v is the enthalpy of water vapor at T_1 . Determination of H_v needs careful consideration. Due to BPE, T_1 will be higher than BP of water at 1atm and the vapor will be produced at T_1 . That means it will not be saturated; rather superheated.
- h_F is the enthalpy of 44% NaOH solution at $T_F = 40^{\circ}\text{C}$ which can be obtained from (21).

Calculations:

Calculate T_1 :

- Using the *Dühring's* plot (Fig. 20), for BP of water 40°C and NaOH concentration 65%, T_1 can be obtained as

$$T_1 = \quad ^{\circ}\text{C} = \quad ^{\circ}\text{F}$$

Calculate h_L :

We need to calculate h_L using Fig.(21). Note the reference state which is "enthalpy of liquid water at 32°F and vapor pressure is zero". Remember that you will have to use this reference for all enthalpy calculations. So you cannot set the reference arbitrarily.

Now to calculate h_L

Step 1 : Locate $x_1 = \quad$ on the horizontal axis on.

Step 2 : Draw a vertical line through x_1 to reach the curve for $T_1 = \quad ^{\circ}\text{F}$.

Step 3: Draw a horizontal line through the intersection of the vertical line through and curve for T_1 . Read h_L from the y axis

$$h_L = \text{Btu/lb} \times \frac{2.326 \text{kJ/Kg}}{1 \text{Btu/lb}} = \text{kJ/kg}$$

Calculate H_v :

V is saturated vapor at $T_1 = 109.5^\circ\text{C} = 229^\circ\text{F}$. We can calculate H_v using steam table. Remember the reference state enthalpy of saturated water at 32°F to be zero. Using the steam table (Appendix 7), at $40^\circ\text{C} = 104^\circ\text{F}$, the enthalpy of saturated vapor is

Btu/lb. To obtain the enthalpy of the superheated vapor

$$\begin{aligned}
 H_v(\text{sup}) &= H_v(\text{sat}) + C_p \Delta T \\
 &= \text{Btu/lb} \\
 &\quad + (0.45 \text{ Btu/lb.}^\circ\text{F})(\quad - \quad)^\circ\text{F} \\
 &= \text{Btu/lb}
 \end{aligned}$$

Calculate h_F :

h_F is the enthalpy of 44% NaOH solution at $40^\circ\text{C} = \quad ^\circ\text{F}$. Following the same procedure as that for h_L we get

$$h_F = \text{Btu/lb} \times \frac{2.326 \text{ kJ/Kg}}{1 \text{ Btu/lb}} = \text{kJ/kg}$$

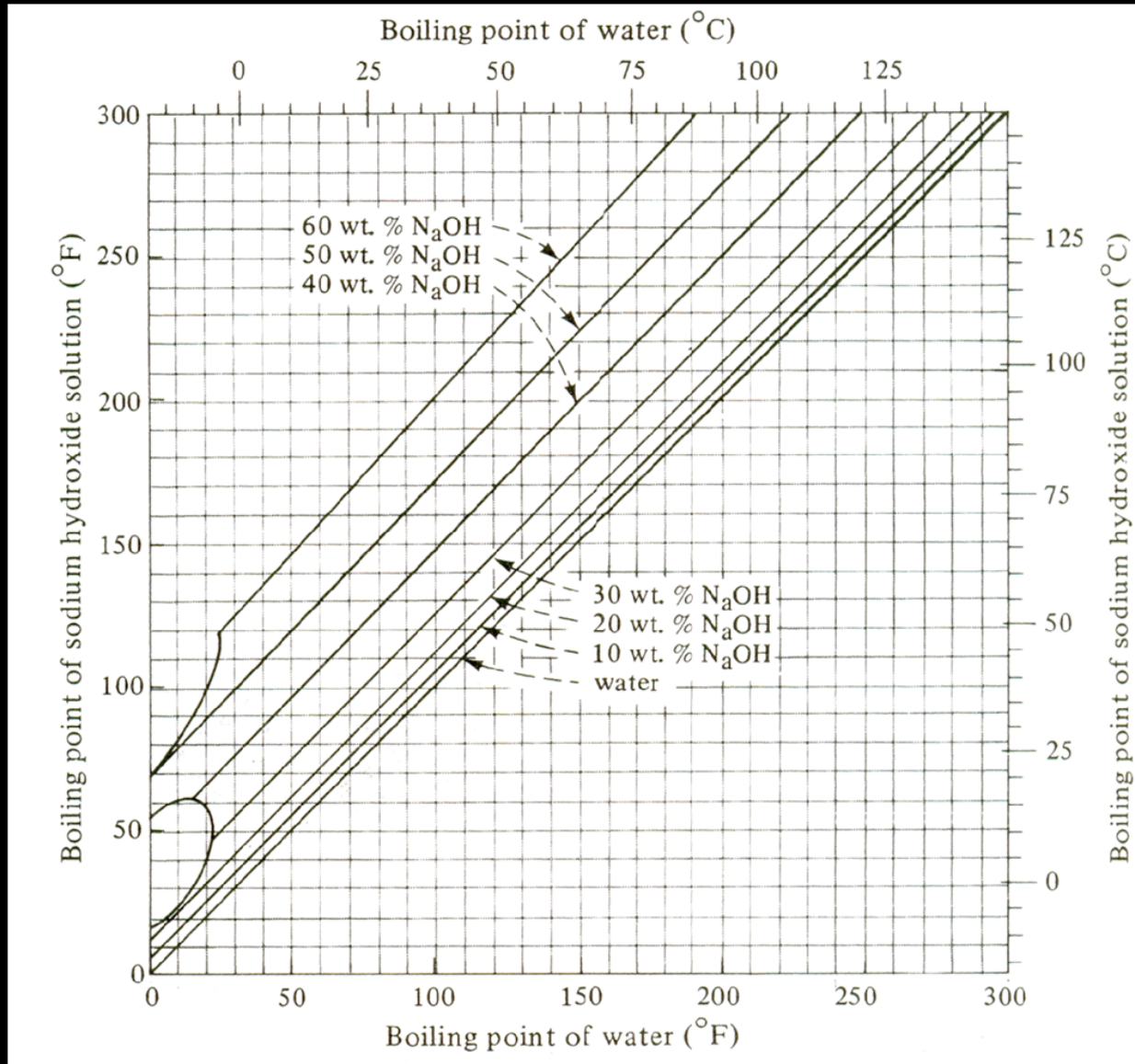

Figure 23: *Dühring's* plot for aqueous $NaOH$ solution.

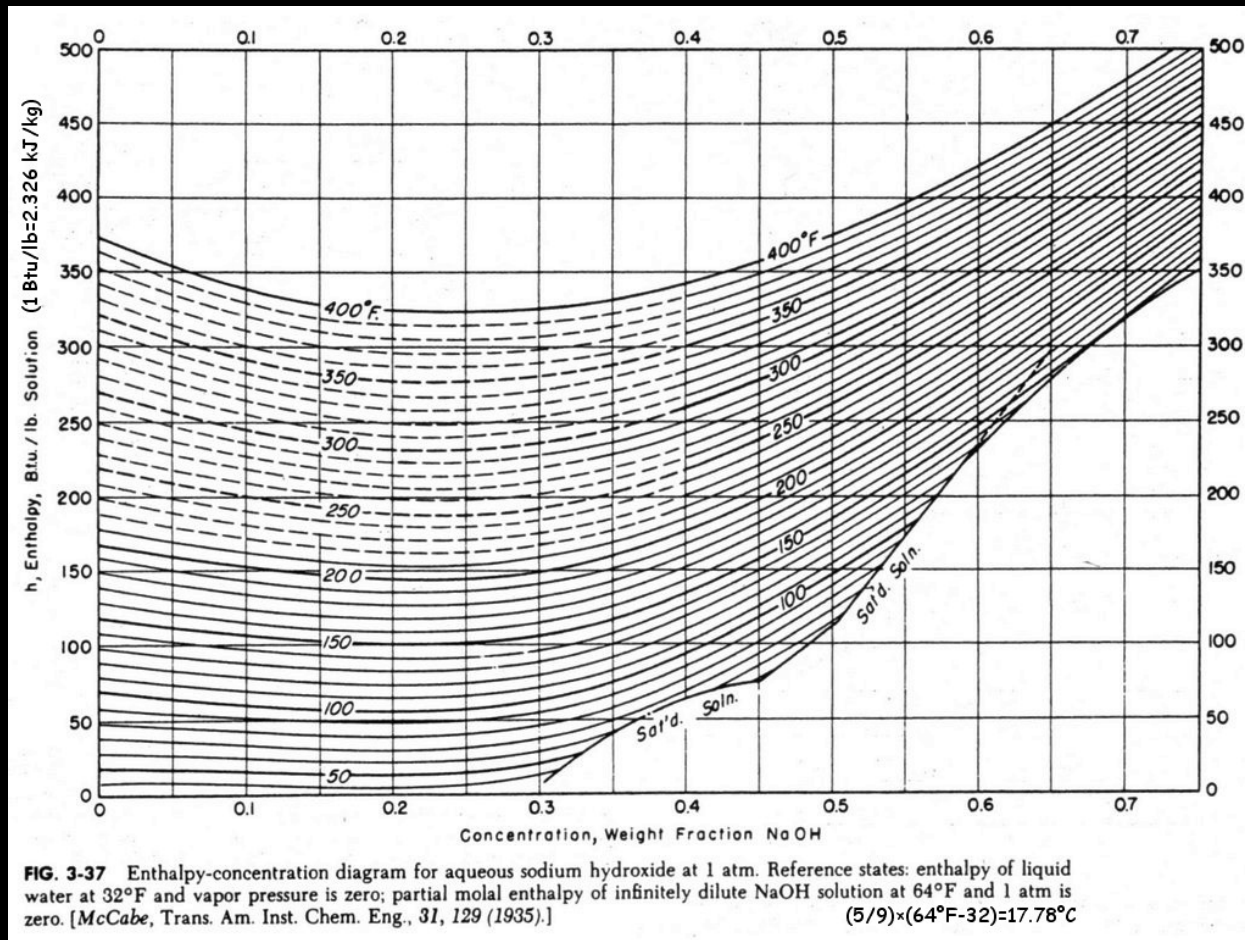

Figure 24: Enthalpy concentration diagram for aqueous $NaOH$ solution.

References

1. W. L. McCabe, J. C. Smith, P. Harriott. (2005). Unit Operations of Chemical Engineering, 7th Edition, McGraw Hill, New York, USA. ISBN-13: 978-0-07-284823-6
2. D. Green and R.H. Perry. 2007. Perry's Chemical Engineers' Handbook, 8th Edition, McGraw-Hill. ISBN-13: 9780071422949
3. C. J. Geankoplis. (2003). Transport Processes and Separation Process Principles, Fourth Ed., Prentice Hall, NJ, USA. ISBN 0-13-101367-X